

NOARK®

Catalog 9FP Series Fuse & Fuse Holder



Company Overview

About us

NOARK Electric is a global manufacturer of low-voltage electrical components for industrial applications. We specialize in motor controls and circuit protection for original equipment manufacturers. Our mission is to provide customers with the highest quality products at an exceptional value and back them with world-class service and support. Every NOARK product is tested and certified to the highest industry standards and covered by our exclusive five-year limited warranty.

Research and Development

The entire portfolio of high-quality NOARK products is designed for manufacturing and assembly (DFMA). Each component is developed in-house by our engineering team to meet the strictest standards and performance requirements. This dedication to excellence has led to the development of patented technology found in many of our products.

World-class Manufacturing

After being thoroughly tested, approved and certified – each NOARK product is sent into production at our state-of-the-art manufacturing facilities. This allows us to maintain strict quality control standards throughout the manufacturing process. In addition, NOARK Electric adheres to a policy of environmental protection and sustainability.

North American Distribution

NOARK's primary distribution center is located in Pomona, CA, with the aim of ensuring prompt and reliable deliveries of the entire product range to our customers all over North America. Our supply chain team works closely with our factories and logistics partners to ensure the availability of our products on the North American market and provide logistics services on the level which our customers expect.

NOARK Electric is a wholly subsidiary of the largest electrical manufacturing group in Asia with over 30 thousand employees and sales revenue of \$10 billion USD. We have corporate facilities in Los Angeles, Shanghai and Prague to service the requirements of individual markets and countries.

140+
Countries

300+
Overseas Distributors

20
Overseas Subsidiaries

22
Logistics Centers

3
R & D Centers

10,000,000+
Sq.Ft. Manufacturing Space

30,000+
Employees Worldwide



9FP-30H Fuse & 9FP30H Fuse Holder

Table of Contents

1 9FP-30H Fuse

Description	01
Features	01
Certifications	01
Product selection guide	02
Specifications	03

2 9FP30H Fuse Holder

Description	04
Features	04
Certifications	04
Product selection guide	05
Specifications	06

9FP-30H Fuse

Description



Description

9FP series DC fuses and fuse holders are mainly used in DC junction box, string inverters, and converter of energy storage system in order to protect and isolate photovoltaic cell modules, arrays and chemical energy (storage) batteries.

Features

- Rated operational voltage 1500 V DC
- 20 kA interrupting rating
- 22mm installation per pole

Certifications

- UL / CE / RoHS
- UL 248-19

9FP-30H Fuse

Product Selection Guide

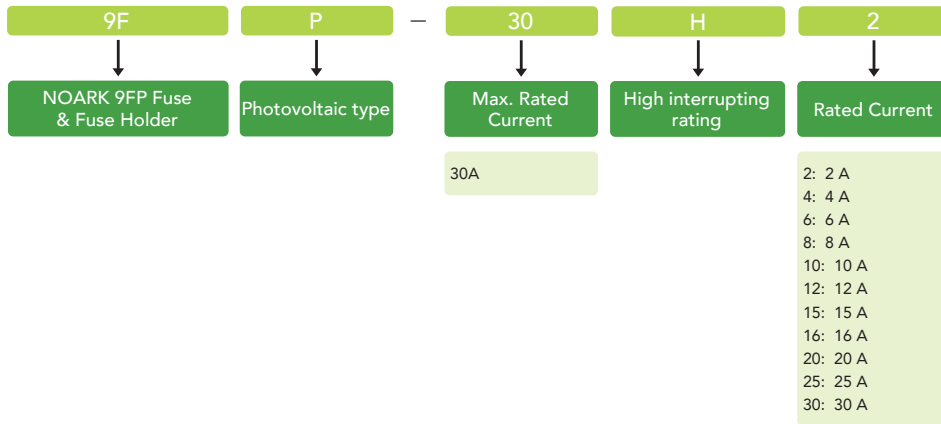

Part Number	Product	Description
1002549	9FP-30H2	Photovoltaic fuse 2A
1002550	9FP-30H4	Photovoltaic fuse 4A
1002551	9FP-30H6	Photovoltaic fuse 6A
1002552	9FP-30H8	Photovoltaic fuse 8A
1002553	9FP-30H10	Photovoltaic fuse 10A
1002554	9FP-30H12	Photovoltaic fuse 12A
1002555	9FP-30H15	Photovoltaic fuse 15A
1002556	9FP-30H16	Photovoltaic fuse 16A
1002557	9FP-30H20	Photovoltaic fuse 20A
1002558	9FP-30H25	Photovoltaic fuse 25A
1002559	9FP-30H30	Photovoltaic fuse 30A

9FP-30H Fuse Specifications

9FP-30H series DC fuse	
UL248-19	
Voltage Rating (V DC)	1500
Amperage Rating In (A)	2, 4, 6, 8, 10, 12, 15, 16, 20, 25, 30
Interrupting rating (kA)	20
Maximum power loss(W)	≤ 10
Dimensions (mm)	10.3*85

Temperature Derating Curve (Temperature of Air Immediately Surrounding Fuse)

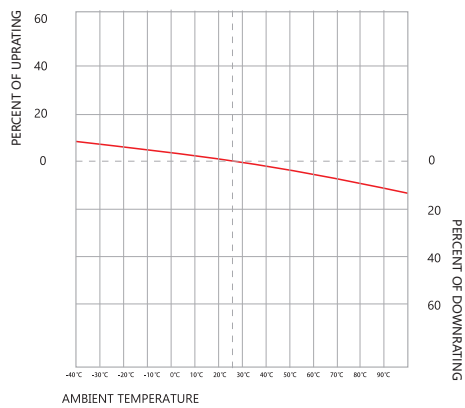

Time Current Curve (2~30A)

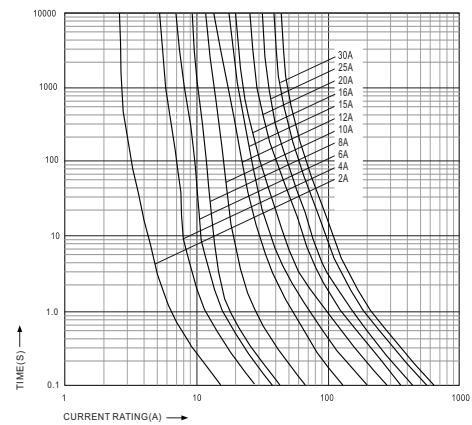

Dimension

Unit: in [mm]
1 in = 25.4 mm

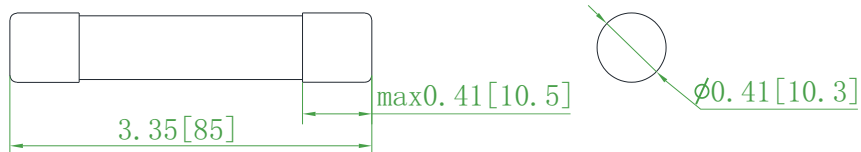

9FP30H Fuse holder

Description



Description

The rated operating voltage of 9FP30H fuse holder is 1500Vdc.

Features

- DC fuse holder for PV systems
- Standard TH35 DIN rail mounting
- Rated current up to 30A
- Rated operational voltage 1500Vdc

Certifications

- EN 60947-3
- UL 4248-19

9FP30H Fuse holder

Product selection guide

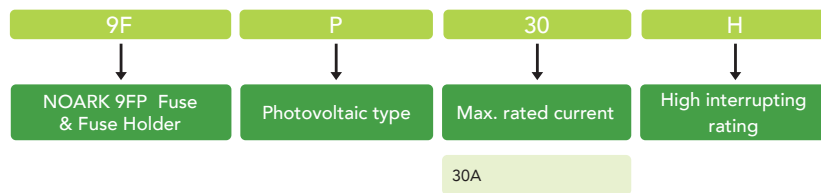

Part Number	Product	Description
1002548	9FP30H	Photovoltaic fuse holder

9FP30H Fuse holder

Specifications

9FP30H Fuse holder		
Conformed Standard	UL 4248-19	
Rated Operational Voltage U_e (V DC)	1500V	
Rated Current I_n (A)	up to 30A	
Maximum Power Loss(W)	≤ 10	
Protection Degree	IP20	
Mounting	TH35-7.5/DIN35 rail	
Operation Temperature Range $^{\circ}$ C	-35~+70	
Humidity	Class II	
Altitude ft (m)	Does not exceed 6,561 (2,000)	
Atmospheric Conditions	At 68 $^{\circ}$ F (+20 $^{\circ}$ C), the relative humidity does not exceed 95%	
	At 104 $^{\circ}$ F (+40 $^{\circ}$ C), the relative humidity does not exceed 50%	
Installation class	Class III	
Installation Environment	No significant vibration or shock	
Wiring	Screw Size	M5
	Tightening Torque (N.m)	2-3.5
	Wiring Range (mm ²)	1~25

Dimension

Unit: in [mm]
1 in = 25.4 mm

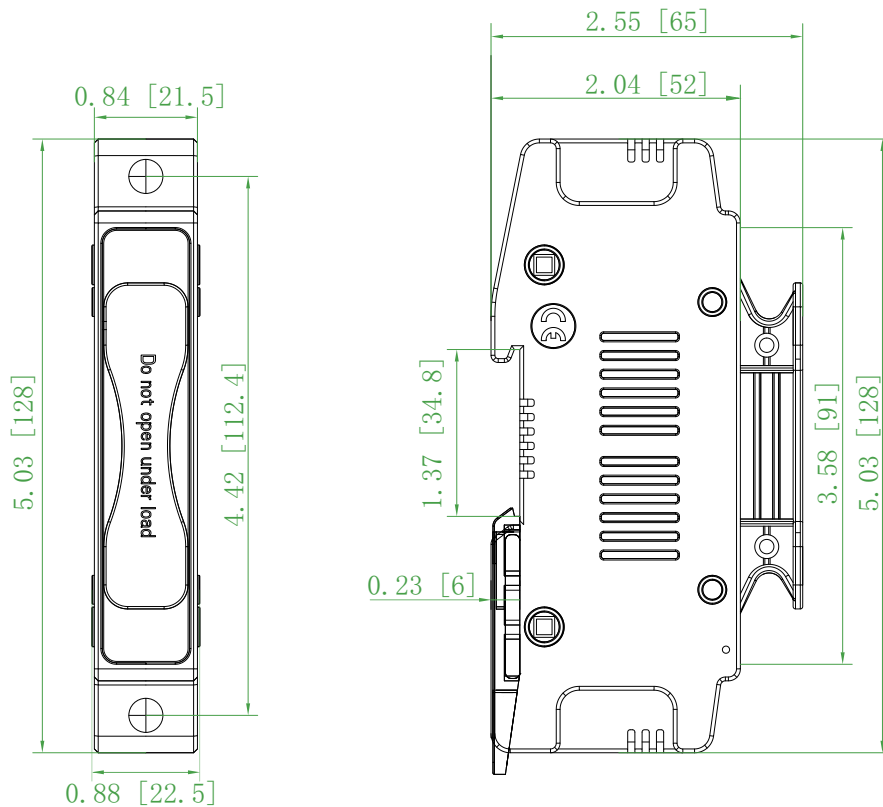

NOARK®



NOARK Electric North America
(626) 330-7007

na.noark-electric.com • nasales@noark-electric.com



Note: NOARK Electric reserves the right to make technical changes or modify the contents of this document without prior notice. With regard to purchase orders, the agreed particulars shall prevail. NOARK Electric nor any of its affiliates or subsidiaries shall be responsible or liable for potential errors or possible lack of information in this document. NOARK Electric reserves all rights in this document and in the subject matter and illustrations contained therein. Any reproduction, disclosure to third parties or utilization of its contents – in whole or in parts – is forbidden without prior written consent of NOARK Electric.