

NJR5-ZX Series  
Soft starter

---

# User Manual

---

# Preface

---

Thank you for choosing NJR5-ZX series soft starter from Zhejiang Chint Co., Ltd.!

NJR5-ZX series soft starter is an on-line soft starter. Its input voltage (main circuit voltage) is AC220V, AC380V, AC460V, AC575V and AC690V respectively. With the characteristics of strong load adaptability, stable and reliable operation, it is widely used in motor transmission equipment in metallurgy, petroleum, fire control, mining, water supply, municipal, food, cement, petrochemical and other fields. It is the the most ideal replacement product for traditional star-delta starting and self-coupling step-down starting.

NJR5-ZX series soft starter is a three-phase AC asynchronous motor (hereinafter referred to as motor) soft starter designed based on power electronics technology, microprocessor technology and modern control theory technology. The product realizes soft start, soft stop and other functions of the motor by controlling the triple opposite parallel thyristor connected in series between the power supply and the controlled motor. The product can effectively control the starting current and starting torque of the motor.

To make the soft starter has better performance, please read the operation manual carefully before starting it. For your safety and reasonable use, **please read and execute the contents marked with "⚠" and "⚡" in the instruction manual carefully.** If you have any doubts in the process of use, please contact us, our professionals are happy to help you.

Our company will continuously optimize and improve NJR5-ZX series soft starters, and the changes related to the instructions will be reflected in the version change record in Appendix C.

## Safety Warning

---

- ① When installed in the cabinet, the exhaust fan must be installed to ensure the air circulation in the cabinet and prolong the service life of the product;
- ② When the output of soft starter and frequency converter are used as backup, the output ends of the two should be isolated from each other. (That means, before the frequency converter runs the motor, make sure that the output end of the soft starter is disconnected from the input end of the motor and the output end of the frequency converter; Before the soft starter runs the motor, make sure that the output end of the frequency converter is disconnected from the input end of the motor and the output end of the soft starter);
- ③ After the input end of the soft starter is powered on, when the load is open, the output end of the soft starter will still have an induced voltage even in the stopped state, which is caused by the leakage current of the thyristor, which is a normal phenomenon. After connecting to the motor, the induced voltage can disappear, so pay attention to the danger of electric shock when using;
- ④ In the distribution circuit, if the reactive power compensation equipment to improve the power factor or pure capacitive equipment needs to be installed, it should be connected to the input end of the soft starter, strictly prohibited to be directly connected to its output end, otherwise the soft starter will be damaged;
- ⑤ The product is strictly prohibited to be installed in the environment containing flammable, explosive and strong corrosive gases and condensation;
- ⑥ After the product is powered on, do not touch the conductive part of the product or operate the product with wet hands.
- ⑦ When installing, maintaining and maintaining the product, ensure that the line has been cut off;
- ⑧ Children are forbidden to play with unsealed products or packaging;
- ⑨ There should be enough space and safe distance around the installation of the product;
- ⑩ When installing the product, use standard cable (including copper bar) and peripheral device configuration;
- ⑪ In order to avoid dangerous accidents, the installation and fixation of the product shall be carried out in strict accordance with the requirements of the manual;
- ⑫ After removing the package, check whether the product is damaged and check the integrity of the item;
- ⑬ When installing live wires outside the product, insulate exposed wires to prevent accidental electric shock;
- ⑭ The product has been strictly tested for dielectric strength before leaving the factory. In order to prevent accidental leakage of the product shell, please reliably connect the grounding end of the product to the earth.

# Catalogue

---

<b>1</b>	Main Use, Scope of Application and Characteristics	01
	1.1 Unpacking inspection	01
	1.2 Main use	01
	1.3 Scope of application	01
	1.4 Characteristics	01
	1.5 Model specification	02
	1.6 Product selection	03
<b>2</b>	Normal use, installation, transportation and storage conditions	06
	2.1 Normal use, transportation and storage conditions	06
<b>3</b>	Main technical parameters and performance	07
	3.1 Main technical parameters and performance	07
<b>4</b>	Structural Characteristics and Working Principle	08
	4.1 Overall structure and principle	08
	4.2 Structure and working principle of main components or functional units	09
<b>5</b>	Appearance and installation size and weight	14
	5.1 Shape and installation size of soft starter	14
	5.2 Soft starter weight	16
<b>6</b>	Installation, Debugging and Operating Guide	17
	6.1 Precautions for installation	17
	6.2 Inspection work before and after power on	17
	6.3 Methods for test run	17

6.4	Description of operation panel, supporting board and door	17
6.5	Function settings	19
6.6	Fault log explained	20
6.7	Definition and description of parameters	21
<b>7</b>	<b>RS485 communication</b>	<b>37</b>
7.1	Communication connection	37
7.2	content of agreement	38
7.3	protocol format	38
7.4	Test code generation mode	39
7.5	Description of function code	46
7.6	Description of functional exception code	46
7.7	Communication address	46
7.8	Example of Modbus communication	51
<b>8</b>	<b>Fault analysis and troubleshooting</b>	<b>52</b>
8.1	Maintenance	52
8.2	Fault protection instructions	52
8.3	Analysis and troubleshooting methods of common fault names	56
8.4	Analysis and elimination methods of common abnormal phenomena	56
<b>9</b>	<b>Warranty period and environmental protection</b>	<b>62</b>
9.1	Warranty period	62
9.2	Environmental protection	62
<b>Appendix A Recommended Table of Peripheral Device Configuration</b>		<b>63</b>
<b>Appendix B Application</b>		<b>66</b>
<b>Appendix C version change record form</b>		<b>71</b>

## 1 Main Use, Scope of Application and Characteristics

### 1.1 Unpacking inspection

1.1.1 Whether the nameplate model of this machine is consistent with your order form, in addition to the product itself, each soft starter packing box should also have instructions for use of supporting products (including certificate);

1.1.2 Check whether the soft starter is damaged during transportation; If any damage is found, please contact the supplier immediately.

### 1.2 Main use

It is mainly used for soft start and soft stop of the motor, etc. By reducing the starting voltage and current, the motor can start stably and reliably, thus reducing the impact on the equipment during starting, reducing the damage to the equipment and prolonging the service life. At the same time, the soft starter also has the basic protection function of the motor comprehensive protector.

### 1.3 Scope of application

It is suitable for common squirrel-cage three-phase asynchronous motor. The main load types of the motor are: fan, water pump, compressor, ball mill, crusher and other loads.

### 1.4 Characteristics

#### 1.4.1 Aspects of performance

- **Seven kinds of nominal current mode:** normal current mode, enhanced current mode, normal voltage mode, enhanced voltage mode, linear torque mode, square torque mode and frequency division mode. Choosing different starting modes and starting parameter settings according to load characteristics can make the motor achieve the best starting effect to the greatest extent;
  - **Smooth jump:** When switching from the sudden jump process to the normal starting mode, the current realizes seamless and smooth docking without sudden change, thus prolonging the service life of the transmission equipment;
  - **Torque control mode:** control the output electromagnetic torque of the soft starter in real time, so that the speed of the motor rises more smoothly in the process of soft starting;
  - **Light-load energy saving:** when selecting the energy-saving mode, when the motor is detected to be in the light-load operation state, appropriately reduce the output voltage of the soft starter → motor magnetic flux drop → excitation current drop → iron loss drop → stator current drop → stator copper loss drop → soft starter output power drop, so as to realize energy saving;
  - **Low-speed forward rotation and reverse rotation function:** by adjusting the trigger angle of thyristor, the product has the switching function of low-speed forward rotation and low-speed reverse rotation to meet some application functions, such as water pump cleaning;
  - **It has the function of braking and stopping:** by injecting direct current into the motor, it can quickly stop and meet some application functions;
  - **Wide input frequency:** in current mode, the power frequency ranges from 35 Hz to 60 Hz, which is more suitable for generator occasions.
- #### 1.4.2 Aspects of functional
- **With secondary current limiting function:** in some heavy load occasions, when the motor can't get up after primary current limiting, you can choose secondary current limiting (secondary current limiting multiple is larger than primary current limiting multiple) to start the motor, and finally make the motor run at full speed;

- when 2-3 motors are started in sequence, the 2nd and 3rd motor parameters are selected through the logic input control of external control terminal signals IN1 and IN2, and the starting, stopping and running overload protection is carried out according to the 2nd and 3rd motor parameters, which is especially suitable for the applications of one-tow-two, one-tow-three and two-speed motors;
- **Various protect functions:** it has faults such as input phase loss, output phase loss, three-phase unbalance, operation overload, starting current limit timeout, main circuit overvoltage, main circuit undervoltage, load locked/short circuit, too long starting time and too many starting times, which effectively protects the soft starter and the motor;
- **Four analog current outputs:** 4mA~20mA, 0mA~20mA, 2mA~10mA and 0mA~10mA, which are better compatible with industrial automation equipment or instruments;
- **Built-in RS485 communication interface:** The standard Modbus protocol is adopted to realize the communication between the soft starter and the upper computer, and the degree of automation is greatly improved.

#### 1.4.3 Aspects of user use

- **User's convenient for debugging:** when the load type is selected (see F2.00 or F3.00 or F4.00), the starting parameters related to the motor will be automatically configured to facilitate user's debugging;
- **User's convenient for installation:** the wiring mode is sampling three in and three out, which is very convenient for installation;
- **Easy operability:** liquid crystal display, friendly interface and convenient operation;
- **Record 10 pieces of faults information:** record the working state, product temperature, working current and working voltage at the moment of fault occurrence, which is convenient for troubleshooting, analysis and solution.

#### 1.4.4 Aspects of stability

- Enhanced coating process is used for PCBA protection, which greatly improves the stability of the product.
- Enhanced EMC design, higher EMS interference resistance and high stability.

#### 1.5 Model specification

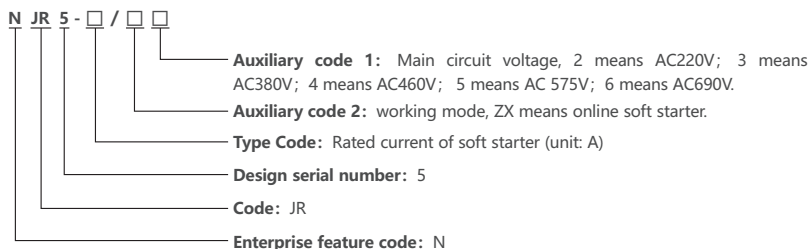

#### Example:

NJR5-150/ZX3 means a soft starter with rated current 150A and rated voltage 380V. Its adaptive motor is a three-phase squirrel-cage asynchronous motor with power 75kW and rated voltage 380V.

#### Selection principle:

- 1) It is recommended to choose the first gear under heavy load;
- 2) It is recommended to choose a larger grade for AC 460 V, AC575V and AC690V voltage grade products.

**1.6 Product selection**

See tables 1.1a), 1.1b), 1.1c), 1.1d) and 1.1e) respectively.

**Table 1.1a)NJR5-15/ZX2~NJR5-1000/ZX2 Selection Table**

Product model	Rated voltage	Rated model current	Adaptive motor rated current	Adapting motor rated power
NJR5-15/ZX2	AC220V	15A	15A	4kW
NJR5-22/ZX2	AC220V	22A	22A	5.5kW
NJR5-30/ZX2	AC220V	30A	29A	7.5kW
NJR5-37/ZX2	AC220V	37A	36A	11kW
NJR5-44/ZX2	AC220V	44A	42A	11kW
NJR5-60/ZX2	AC220V	60A	57A	15kW
NJR5-74/ZX2	AC220V	74A	70A	18.5kW
NJR5-90/ZX2	AC220V	90A	84A	22kW
NJR5-110/ZX2	AC220V	110A	103A	30kW
NJR5-150/ZX2	AC220V	150A	140A	37kW
NJR5-180/ZX2	AC220V	180A	167A	45kW
NJR5-220/ZX2	AC220V	220A	207A	55kW
NJR5-264/ZX2	AC220V	264A	248A	75kW
NJR5-320/ZX2	AC220V	320A	300A	90kW
NJR5-370/ZX2	AC220V	370A	349A	110kW
NJR5-440/ZX2	AC220V	440A	404A	110kW
NJR5-500/ZX2	AC220V	500A	459A	132kW
NJR5-560/ZX2	AC220V	560A	514A	160kW
NJR5-630/ZX2	AC220V	630A	579A	160kW
NJR5-710/ZX2	AC220V	710A	634A	200kW
NJR5-800/ZX2	AC220V	800A	720A	200kW
NJR5-900/ZX2	AC220V	900A	810A	250kW
NJR5-1000/ZX2	AC220V	1000A	900A	250kW

**Table 1.1b)NJR5-15/ZX3~NJR5-1000/ZX3 Selection Table**

Product model	Rated voltage	Rated model current	Adaptive motor rated current	Adapting motor rated power
NJR5-15/ZX3	AC380V	15A	15A	7.5kW
NJR5-22/ZX3	AC380V	22A	22A	11kW
NJR5-30/ZX3	AC380V	30A	29A	15kW
NJR5-37/ZX3	AC380V	37A	36A	18.5kW
NJR5-44/ZX3	AC380V	44A	42A	22kW
NJR5-60/ZX3	AC380V	60A	57A	30kW
NJR5-74/ZX3	AC380V	74A	70A	37kW
NJR5-90/ZX3	AC380V	90A	84A	45kW
NJR5-110/ZX3	AC380V	110A	103A	55kW
NJR5-150/ZX3	AC380V	150A	140A	75kW
NJR5-180/ZX3	AC380V	180A	167A	90kW
NJR5-220/ZX3	AC380V	220A	207A	110kW
NJR5-264/ZX3	AC380V	264A	248A	132kW
NJR5-320/ZX3	AC380V	320A	300A	160kW
NJR5-370/ZX3	AC380V	370A	349A	185kW



Table 1.1b)(Continued)

Product model	Rated voltage	Rated model current	Adaptive motor rated current	Adapting motor rated power
NJR5-440/ZX3	AC380V	440A	404A	220kW
NJR5-500/ZX3	AC380V	500A	459A	250kW
NJR5-560/ZX3	AC380V	560A	514A	280kW
NJR5-630/ZX3	AC380V	630A	579A	315kW
NJR5-710/ZX3	AC380V	710A	634A	355kW
NJR5-800/ZX3	AC380V	800A	720A	400kW
NJR5-900/ZX3	AC380V	900A	810A	450kW
NJR5-1000/ZX3	AC380V	1000A	900A	500kW

Table 1.1c)NJR5-15/ZX4~NJR5-1000/ZX4 Selection Table

Product model	Rated voltage	Rated model current	Adaptive motor rated current	Adapting motor rated power
NJR5-15/ZX4	AC460V	15A	15A	9kW
NJR5-22/ZX4	AC460V	22A	22A	15kW
NJR5-30/ZX4	AC460V	30A	29A	18.5kW
NJR5-37/ZX4	AC460V	37A	36A	22kW
NJR5-44/ZX4	AC460V	44A	42A	30kW
NJR5-60/ZX4	AC460V	60A	57A	37kW
NJR5-74/ZX4	AC460V	74A	70A	45kW
NJR5-90/ZX4	AC460V	90A	84A	55kW
NJR5-110/ZX4	AC460V	110A	103A	75kW
NJR5-150/ZX4	AC460V	150A	140A	90kW
NJR5-180/ZX4	AC460V	180A	167A	110kW
NJR5-220/ZX4	AC460V	220A	207A	132kW
NJR5-264/ZX4	AC460V	264A	248A	150kW
NJR5-320/ZX4	AC460V	320A	300A	185kW
NJR5-370/ZX4	AC460V	370A	349A	220kW
NJR5-440/ZX4	AC460V	440A	404A	250kW
NJR5-500/ZX4	AC460V	500A	459A	280kW
NJR5-560/ZX4	AC460V	560A	514A	315kW
NJR5-630/ZX4	AC460V	630A	579A	355kW
NJR5-710/ZX4	AC460V	710A	634A	400kW
NJR5-800/ZX4	AC460V	800A	720A	450kW
NJR5-900/ZX4	AC460V	900A	810A	560kW
NJR5-1000/ZX4	AC460V	1000A	900A	560kW

Table 1.1d)NJR5-15/ZX5~NJR5-1000/ZX5 Type Selection Table

Product model	Rated voltage	Rated model current	Adaptive motor rated current	Adapting motor rated power
NJR5-15/ZX5	AC575V	15A	15A	11kW
NJR5-22/ZX5	AC575V	22A	22A	18.5kW
NJR5-30/ZX5	AC575V	30A	29A	22kW
NJR5-37/ZX5	AC575V	37A	36A	30kW
NJR5-44/ZX5	AC575V	44A	42A	30kW
NJR5-60/ZX5	AC575V	60A	57A	45kW

**Table 1.1d)(Continued)**

Product model	Rated voltage	Rated model current	Adaptive motor rated current	Adapting motor rated power
NJR5-74/ZX5	AC575V	74A	70A	55kW
NJR5-90/ZX5	AC575V	90A	84A	75kW
NJR5-110/ZX5	AC575V	110A	103A	75kW
NJR5-150/ZX5	AC575V	150A	140A	110kW
NJR5-180/ZX5	AC575V	180A	167A	132kW
NJR5-220/ZX5	AC575V	220A	207A	160kW
NJR5-264/ZX5	AC575V	264A	248A	185kW
NJR5-320/ZX5	AC575V	320A	300A	250kW
NJR5-370/ZX5	AC575V	370A	349A	280kW
NJR5-440/ZX5	AC575V	440A	404A	315kW
NJR5-500/ZX5	AC575V	500A	459A	355kW
NJR5-560/ZX5	AC575V	560A	514A	400kW
NJR5-630/ZX5	AC575V	630A	579A	450kW
NJR5-710/ZX5	AC575V	710A	634A	500kW
NJR5-800/ZX5	AC575V	800A	720A	560kW
NJR5-900/ZX5	AC575V	900A	810A	630kW
NJR5-1000/ZX5	AC575V	1000A	900A	800kW

**Table 1.1e)NJR5-15/ZX6~NJR5-1000/ZX6 Selection Table**

Product model	Rated voltage	Rated model current	Adaptive motor rated current	Adapting motor rated power
NJR5-15/ZX6	AC690V	15A	15A	11kW
NJR5-22/ZX6	AC690V	22A	22A	18.5kW
NJR5-30/ZX6	AC690V	30A	29A	22kW
NJR5-37/ZX6	AC690V	37A	36A	30kW
NJR5-44/ZX6	AC690V	44A	42A	37kW
NJR5-60/ZX6	AC690V	60A	57A	55kW
NJR5-74/ZX6	AC690V	74A	70A	75kW
NJR5-90/ZX6	AC690V	90A	84A	90kW
NJR5-110/ZX6	AC690V	110A	103A	110kW
NJR5-150/ZX6	AC690V	150A	140A	132kW
NJR5-180/ZX6	AC690V	180A	167A	160kW
NJR5-220/ZX6	AC690V	220A	207A	200kW
NJR5-264/ZX6	AC690V	264A	248A	250kW
NJR5-320/ZX6	AC690V	320A	300A	315kW
NJR5-370/ZX6	AC690V	370A	349A	355kW
NJR5-440/ZX6	AC690V	440A	404A	400kW
NJR5-500/ZX6	AC690V	500A	459A	400kW
NJR5-560/ZX6	AC690V	560A	514A	500kW
NJR5-630/ZX6	AC690V	630A	579A	560kW
NJR5-710/ZX6	AC690V	710A	634A	630kW
NJR5-800/ZX6	AC690V	800A	720A	710kW
NJR5-900/ZX6	AC690V	900A	810A	800kW
NJR5-1000/ZX6	AC690V	1000A	900A	900kW

## 2 Normal use, installation, transportation and storage conditions

### 2.1 Normal use, transportation and storage conditions

2.1.1 The operating ambient temperature is between  $-10^{\circ}\text{C}$  and  $+40^{\circ}\text{C}$ , between  $+40^{\circ}\text{C}$  and  $+50^{\circ}\text{C}$  should be derated, and the current derated every  $1^{\circ}\text{C}$  increase 2%;

2.1.2 The storage temperature is  $-25^{\circ}\text{C}\sim+70^{\circ}\text{C}$ ;

2.1.3 The relative humidity shall not exceed  $95\%(+20^{\circ}\text{C}\sim+65^{\circ}\text{C})$ ;

2.1.4 No condensation, inflammable and explosive gas, conductive dust and good ventilation;

2.1.5 If the altitude exceeds 1,000m, it should be derated accordingly, and the current derated 0.5% for every 100m between 1,000m and 3000m. more than 3000m needs special customization;

2.1.6 Soft starter should try to avoid vibration;

2.1.7 If the on-site ambient temperature is lower than  $-10^{\circ}\text{C}$  or the power has not been on for 18 months, it shall be powered on and preheated for more than 30 minutes before operation.

### 2.2 Installation conditions

In order to ensure that the soft starter has good ventilation and heat dissipation conditions in use, soft start should be installed vertically and there is enough heat dissipation space around the equipment, as shown in Figure 2.1.

When installed in the cabinet, an exhaust fan must be installed to ensure that Air circulation in the cabinet can prolong the service life of products.

The soft starter is only allowed to be installed by professionals. Read this manual carefully before loading.

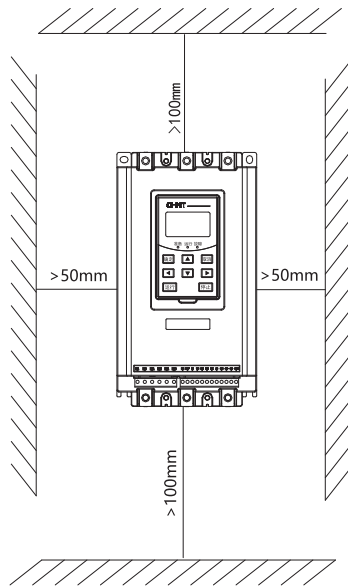

Figure 2.1 Product installation peripheral space

**Note:** When installed in the cabinet, an exhaust fan must be installed to ensure the air circulation in the cabinet.

### 3 Main technical parameters and performance

#### 3.1 Main technical parameters and performance

**Table 3.1 Main technical parameters and performance**

Serial number	Technical parameter	Specification and performance index
1	Main power voltage	NJR5-□/ZX2:AC220V(-10%~+15%) (AC198V~AC264V) NJR5-□/ZX3:AC380V(-15%~+15%) (AC323V~AC437V) NJR5-□/ZX4:AC460V(-10%~+10%) (AC414V~AC504V) NJR5-□/ZX5:AC575V(-10%~+10%) (AC517V~AC633V) NJR5-□/ZX6:AC690V(-10%~+10%) (AC621V~AC759V)
2	Main power frequency	1. When the starting mode is current mode (more suitable for generator occasions): 35Hz~60Hz. 2. When the starting mode is non-current mode: 50Hz±2Hz and 60Hz±2Hz.
3	Applicable motor	Ordinary squirrel-cage three-phase asynchronous motor
4	Class of pollution	Level 3
5	Rated insulation voltage	NJR5-□/ZX2 and NJR5-□/ZX3: AC 660 V NJR5-□/ZX4, NJR5-□/ZX5 and NJR5-□/ZX6:AC1000V
6	Rated impulse withstand voltage	8kV
7	Cooling mode	air blast cooling
8	Starting frequency	It is recommended that the hourly frequency can be set, and it is recommended that it should not exceed 10 times/hour (the heavier the load, the less the starting frequency should be. If frequent starting is really necessary, the temperature of the motor and the soft starter should be kept at a lower temperature). <b>Note: When starting current limit timeout protection or running overload protection is reported, it can be started again after 30 minutes.</b>
9	Shock resistance	The vibration is less than 0.5g
10	EMC equipment level	Class A (industrial grade)
11	Initial voltage	30%Ue~70%Ue
12	Limiting starting current	50%le~500%le
13	Overload protection level	Level 2, 10A, 10, 20 and 30
14	Relay output	Three relay outputs, online/bypass relay K1, programmable status relay K2 and programmable fault relay K3.
15	Number input	Two programmable digital inputs: programmable input terminal IN1 and programmable input terminal IN2. Three digital inputs: start signal RUN, STOP signal stop and instant stop signal EMS.
16	Analog output	Four output types: 4mA~20mA, 0mA~20mA, 2mA~10mA and 0mA~10mA.
17	Analog input	One analog input: PTC temperature input.

## 4 Structural Characteristics and Working Principle

### 4.1 Overall structure and principle

4.1.1 General structure diagram, see figure 4.1.

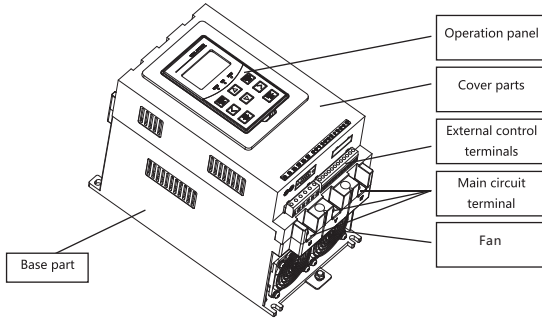

Figure 4.1 Overall Structure Diagram

### 4.1.2 working principle

The main circuit of NJR5-□/ZX series soft starter adopts six thyristors in anti-parallel connection and then serially connected to the stator circuit of AC motor. The trigger angle of the thyristor is controlled by the microprocessor MCU to change the input voltage of the motor and realize the soft start of the motor. When starting is completed, the output voltage of the soft starter is equal to the input voltage, and the soft starter is switched to online operation. See Figure 4.2 for the specific working principle diagram.

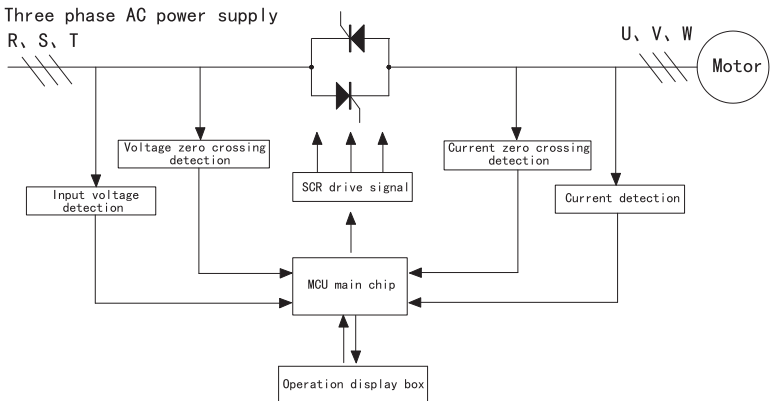

Figure 4.2 Working principle

## 4.2 Structure and working principle of main components or functional units

### 4.2.1 Basic wiring schematic diagram

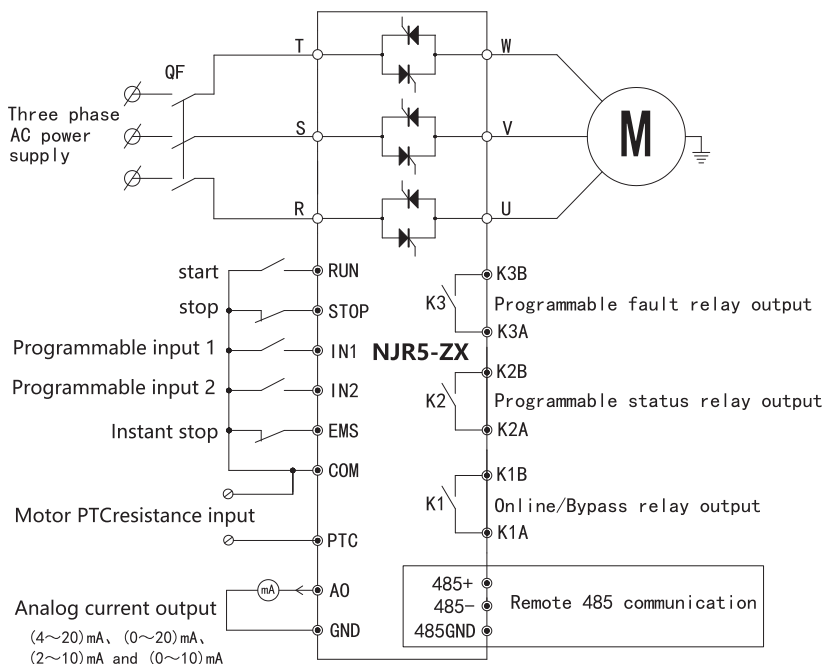

Figure 4.3 Basic wiring schematic diagram

**Note 1:** When the external control terminals are used to control the start and stop, the product is powered on when the stop terminal and COM terminal are closed. The start command can only be given when it is detected that the RUN terminal and COM terminal change from open to closed. If it is powered on, RUN, STOP and COM terminals are always closed, so you won't receive the start command.

**Note 2:** The K2 and K3 relays can be confirmed by modifying the set value of functional parameter F5.00 relay output effective state. Whether the closed state or the open state is the effective state, see F5.00 parameter introduction for details.

### 4.2.2 Definition of main circuit terminals

R, S, T	The soft starter input is also the input of three-phase AC power supply.
U, V, W	The output of soft starter is also the input of three-phase asynchronous motor.

## 4.2.3 Definition of control terminal

**Table 4.1 Definition of Control Terminals**

Terminal name	Terminal definition	Detailed description
K1A, K1B	Online/Bypass relay K1 (default open)	Contact capacity: 5A/250VAC. For controlling high-power contactors, an intermediate relay is required. When the soft starter is switched to online operation, K1A and K1B terminals become closed.
K2A, K2B	Programmable status relay K2 (default open)	Contact capacity: 3A/250VAC. For controlling high-power contactors, an intermediate relay is required. This function is determined by the function parameters F5.00 and F5.13, When the tenth digit of F5.00 is 0, it means that the terminals K2A and K2B are in an effective state when they are closed; When the tenth digit of F5.00 is 1, it means that the terminals K2A and K2B are in an effective state when they are disconnected. <b>Example:</b> If the tenth digit of F5.00 is set to 0, F5.13 is set to 2 (online/bypass state), when the soft starter enters online/bypass operation state, K2A and K2B terminals are closed, while K2A and K2B terminals are disconnected. in other working states; When the tenth digit of F5.00 is set to 1, F5.13 is set to 2 (online/bypass state), and when the soft starter enters online/bypass operation state, K2A and K2B terminals are disconnected. In any other working state, K2A and K2B terminals are closed.
K3A, K3B	Programmable fault relay K3 (default open)	Contact capacity: 3A/250VAC. For controlling high-power contactors, an intermediate relay is required. This function is determined by the function parameters F5.00 and F5.14, When the bit of F5.00 is 0, it means that the terminals K3A and K3B are in an effective state when they are closed; When the bit of F5.00 is 1, it means that the terminals K3A and K3B are in an effective state when they are disconnected. <b>Example:</b> If the bit of F5.00 is set to 0, and F5.14 is set to 0 (any fault or alarm), the K3A and K3B terminals are closed when any fault or alarm occurs in the soft starter, and the K3A and K3B terminals are disconnected when there is no fault or alarm. When the bit of F5.00 is set to 1, F5.14 is set to 0 (any fault or alarm), and K2A and K2B terminals are disconnected when any fault or alarm occurs in the soft starter. When there is no fault or alarm, K3A and K3B terminals are closed.
RUN	Starting terminal RUN	Take COM as the reference point. When the external control starting is allowed, when the RUN terminal and the STOP terminal are closed at the same time, and the closing time is greater than the set values of F5.07 and F5.09, the starting command will be initiated; When the STOP terminal is disconnected, and the disconnection time is greater than the setting value of F5.10, a stop command will be issued.
STOP	STOP terminal stop	<b>Note: This terminal is a dry contact. It is strictly forbidden to introduce external AC/DC power supply.</b>

**Table 4.1 (Continued)**

Terminal name	Terminal definition	Detailed description
IN1	Programmable input terminal IN1	With COM as the reference point, the function is determined by parameter F5.01 <b>Note: This terminal is a dry contact. It is strictly forbidden to introduce external AC/DC power supply.</b>
IN2	Programmable input terminal IN2	With COM as the reference point, the function is determined by parameter F5.02 <b>Note: This terminal is a dry contact. It is strictly forbidden to introduce external AC/DC power supply.</b>
EMS	Instantaneous stop EMS	With COM as the reference point, when it is detected that the disconnection time between EMS terminal and COM terminal is greater than the set value of parameter F5.12, the fault of "open circuit of instantaneous stop terminal" is reported. <b>Note: This terminal is a dry contact. It is strictly forbidden to introduce external AC/DC power supply.</b>
COM	External control terminal	Is the common terminal for signal input of terminals RUN, STOP, IN1, IN2, EMS and PTC.
PTC	Motor temperature input terminal	COM is used as the reference point for thermal protection of motor. The total resistance of the motor temperature sensor circuit: 200Ω~750Ω at 25°C. When the total resistance is greater than 3.1kΩ, the "motor overheating fault" will be reported, and when the total resistance is less than 1.5kΩ, the motor overheating will be relieved.
AO	Analog output terminal	With GND as the reference point. The output type of AO analog quantity is determined by parameter F6.00, including four output types: 4mA~20mA, 0mA~20mA, 2mA~10mA and 0mA~10mA. The analog output function of AO is determined by F6.01, including motor current Max=500%I <sub>e</sub> , motor current Max=200%I <sub>e</sub> , motor current Max=100%I <sub>e</sub> , main circuit voltage [V], soft starter temperature [C], power factor and electromagnetic torque [100%]. See the introduction of parameters F6.00 and F6.01 for details.
GND	Internal chip working ground	The place where the main chip works is also the place where the analog output AO is located.
485+	RS485 communication terminal 485+	485+ is connected to the differential positive terminal of the upper computer.
485-	RS485 communication terminal 485-	485- is connected to the differential negative terminal of the upper computer.
485GND	Communication terminal RS485 GND	485GND is connected to the ground of the differential power supply of the upper computer, so that the communication ground of the soft starter is directly connected with the communication ground of the upper computer, and the communication is more reliable.



4.2.4 Schematic diagram of control terminal

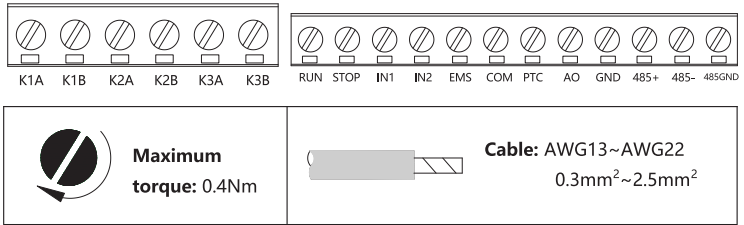

Figure 4.4 Schematic diagram of control terminal

4.2.4 Basic wiring diagram

three phase power supply

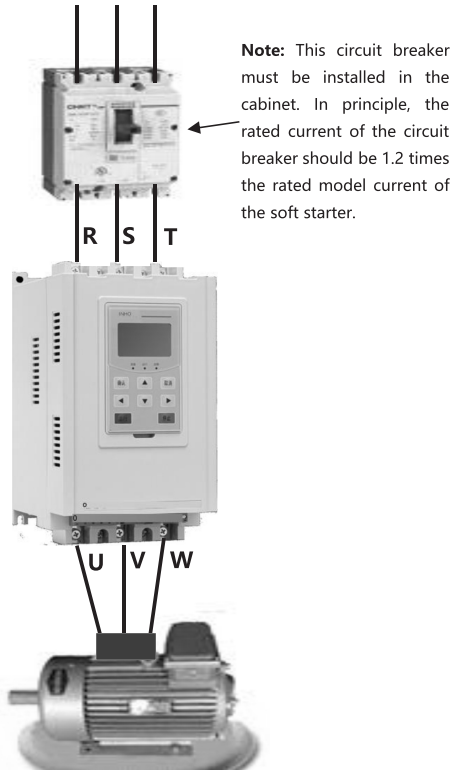



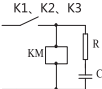

Figure 4.5 Basic wiring diagram

#### 4.2.5 Matters needing attention in wiring of main circuit

Security level	Detailed description
	<ul style="list-style-type: none"> <li>It is strictly forbidden to connect capacitors directly to the output terminals (U, V, W) of the soft starter!</li> <li>When the motor rotates in the wrong direction, the wiring of any two phases in U, V and W should be exchanged!</li> <li>The cables (copper bars) for the main circuit should be in accordance with relevant standards, and there are recommended values in Appendix A for reference!</li> <li>When the installation standard requires the use of incoming leakage current equipment for protection, you must use a leakage circuit breaker to avoid accidental tripping during power-on and check its compatibility with other protection equipment!</li> </ul>
	<ul style="list-style-type: none"> <li>Don't use the main circuit power ON/OFF method to control the operation and stop of the soft starter. After the soft starter is powered on, use the external control terminal or operation panel on the soft starter or remote communication to control the soft start or stop of the soft starter!</li> <li>The soft starter must be grounded to meet the relevant leakage current specifications, and the shell must be reliably grounded. If several soft starters are connected to the same ground line during installation, each soft starter must be grounded separately!</li> <li>The power cable should be isolated from the weak current signal (detector, PLC, measuring instrument) circuit. It is suggested that the power cable should be larger than 20mm, and should be wired vertically to each other as far as possible!</li> </ul>

#### 4.2.6 Matters needing attention in wiring of control circuit

Security level	Matters need attention
	<ul style="list-style-type: none"> <li>It is forbidden to introduce external power to terminals other than K1A, K1B, K2A, K2B, K3A and K3B!</li> <li>If there is a running command after power-on or fault manual reset, the motor will start!</li> </ul>
	<p>Low control line (weak current) and power line (strong current) wiring should keep a distance, should be greater than 20mm, such as cross wiring should be perpendicular to each other!</p> <ul style="list-style-type: none"> <li>When K1, K2 and K3 control external contactors, it is recommended to connect a resistance-capacitance circuit in parallel at both ends of the contactor coil to effectively restrain surge voltage generated during contactor operation and improve the reliability of the system! The following figure:</li> </ul> <div style="text-align: center;">  <p>R: 10Ω ~ 100Ω; C: 0.01μF ~ 1μF</p> </div>

## 5 Appearance and installation size and weight

### 5.1 Shape and installation size of soft starter

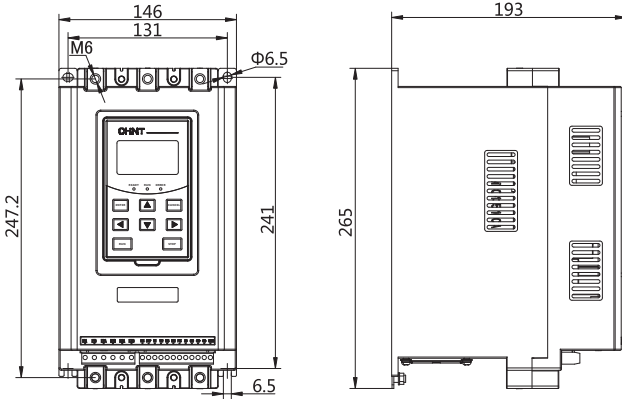

Figure 5.1 NJR5-15/ZX2~NJR5-90/ZX2, NJR5-15/ZX3~NJR5-90/ZX3, NJR5-15/ZX4~NJR5-90/ZX4, NJR5-15/ZX5~NJR5-90/ZX5 And NJR5-15/ZX6~NJR5-90/ZX6 overall outline and installation dimension drawing.

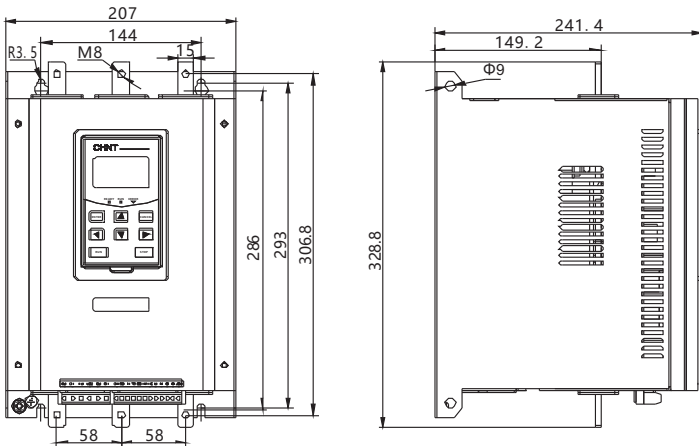

Figure 5.2 NJR5-110/ZX2~NJR5-150/ZX2, NJR5-110/ZX3~NJR5-150/ZX3, NJR5-110/ZX4~NJR5-150/ZX4, NJR5-110/ZX5~NJR5-150/ZX5 And NJR5-110/ZX6~NJR5-150/ZX6 overall outline and installation dimension drawing.

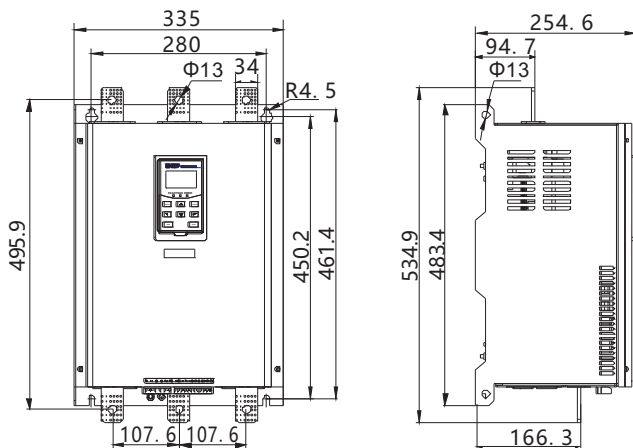

Figure 5.3 NJR5-180/ZX2~NJR5-370/ZX2, NJR5-180/ZX3~NJR5-370/ZX3, NJR5-180/ZX4~NJR5-370/ZX4, NJR5-180/ZX5~NJR5-370/ZX5 And NJR5-180/ZX6~NJR5-370/ZX6 overall outline and installation dimension drawing.

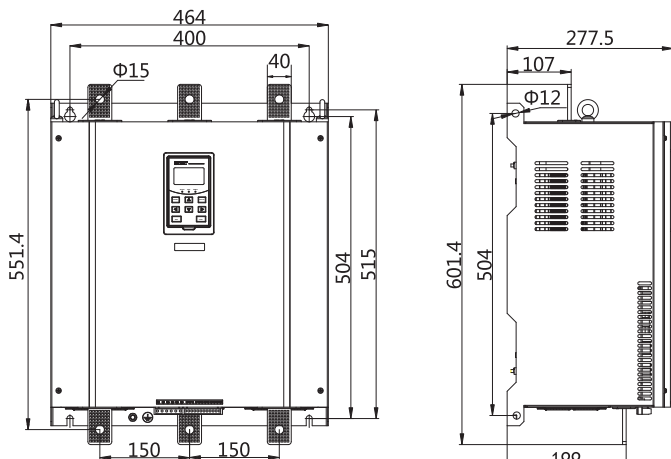
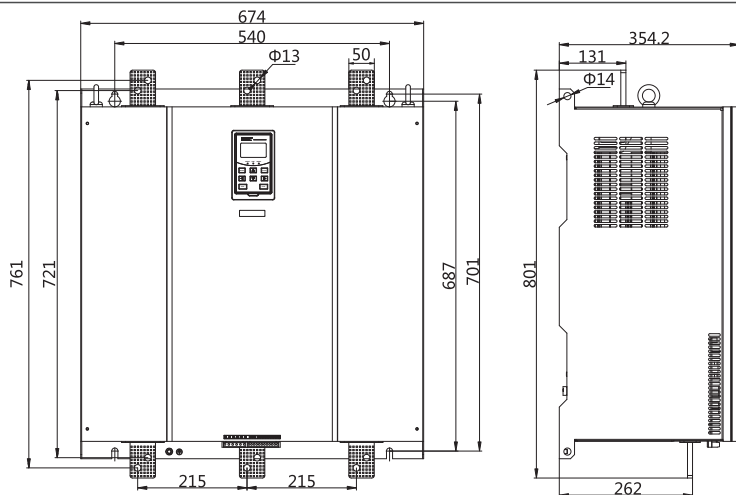

Figure 5.4 NJR5-440/ZX2~NJR5-710/ZX2, NJR5-440/ZX3~NJR5-710/ZX3, NJR5-440/ZX4~NJR5-710/ZX4, NJR5-440/ZX5~NJR5-710/ZX5 And NJR5-440/ZX6~NJR5-710/ZX6 overall outline and installation dimension drawing.



**Figure 5.5 NJR5-800/ZX2~NJR5-1000/ZX2, NJR5-800/ZX3~NJR5-1000/ZX3, NJR5-800/ZX4~NJR5-1000/ZX4, NJR5-800/ZX5~NJR5-1000/ZX5 And NJR5-800/ZX6~NJR5-1000/ZX6 overall outline and installation dimension drawing.**

## 5.2 Soft starter weight

**Table 5.1 Weight of soft starter**

Model	Net weight	Gross weight	Remarks
NJR5-15/ZX2~NJR5-90/ZX2, NJR5-15/ZX3~NJR5-90/ZX3, NJR5-15/ZX4~NJR5-90/ZX4, NJR5-15/ZX5~NJR5-90/ZX5, NJR5-15/ZX6~NJR5-90/ZX6	6.2kg	6.7kg	Figure 5.1
NJR5-110/ZX2~NJR5-150/ZX2, NJR5-110/ZX3~NJR5-150/ZX3, NJR5-110/ZX4~NJR5-150/ZX4, NJR5-110/ZX5~NJR5-150/ZX5, NJR5-110/ZX6~NJR5-150/ZX6	10.2kg	10.8kg	Figure 5.2
NJR5-180/ZX2~NJR5-370/ZX2, NJR5-180/ZX3~NJR5-370/ZX3, NJR5-180/ZX4~NJR5-370/ZX4, NJR5-180/ZX5~NJR5-370/ZX5, NJR5-180/ZX6~NJR5-370/ZX6	24.5kg	26.5kg	Figure 5.3
NJR5-440/ZX2~NJR5-710/ZX2, NJR5-440/ZX3~NJR5-710/ZX3, NJR5-440/ZX4~NJR5-710/ZX4, NJR5-440/ZX5~NJR5-710/ZX5, NJR5-440/ZX6~NJR5-710/ZX6	39.6kg	42.6kg	Figure 5.4
NJR5-800/ZX2~NJR5-1000/ZX2, NJR5-800/ZX3~NJR5-1000/ZX3, NJR5-800/ZX4~NJR5-1000/ZX4, NJR5-800/ZX5~NJR5-1000/ZX5, NJR5-800/ZX6~NJR5-1000/ZX6	80kg	84kg	Figure 5.5

## 6 Installation, Debugging and Operating Guide

### 6.1 Precautions for installation

Please read the requirements of the installation conditions, parameters and other aspects in the previous chapters before the installation of a soft starter.

#### 6.2 Inspection work before and after power on

##### 6.2.1 Inspection work before power on

6.2.1.1 Please confirm that the wiring is correct, the wiring contact is good and the grounding terminal is well grounded.

6.2.1.2 Please confirm that there is no short circuit or ground fault between terminals or exposed live parts;

6.2.1.3 Please confirm that the motor type can match the soft starter;

6.2.1.4 Please check whether the motor insulation meets the requirements or not;

6.2.1.5 Use a multimeter to check whether the three-phase input power supplies (R, S and T) have short circuit or not.

**NOTE: With regard to NJR5-ZX4, ZX5 and ZX6 soft starter, since the input of the built-in transformer is connected with the main circuits S and T, the static resistance when testing S and T terminals shall be 40  $\Omega$  ~ 500  $\Omega$ .**

##### 6.2.2 Inspection work after power on

6.2.2.1 After the power is on, the operation panel should display "Ready";

6.2.2.2  $\Delta$ Parameter F2.01 Please check whether the rated current of the motor is consistent with the rated current on the motor nameplate. If the motor nameplate does not match the value setting, please modify it immediately, or the motor may be burned out;

6.2.2.3 It is a normal phenomenon that U, V and W output terminals have induced voltage when power is on under the circumstance that the soft starter output is not connected to the motor. This induced voltage drop disappears when the motor is connected.

### 6.3 Methods for test run

6.3.1 After confirming that there is no abnormality, the test run can be carried out. When leaving the factory, it defaults to local operation panel mode and external control terminal mode;

6.3.2 Please check whether the running direction of the motor meets the requirements;

6.3.3 Please check whether the motor rotates stably (without vibration and big noise);

6.3.4 If the motor start is not ideal, please adjust the parameters F2.02 (first motor start mode), F2.04( first motor current limiting multiple), F2.07 (first motor initial voltage), F2.08 (first motor soft start time factor), etc;

6.3.5 If the on-site ambient temperature is lower than - 10  $^{\circ}\text{C}$  or the power has not been on for 18 months, it shall be powered on and preheated for more than 30 minutes before operation;

6.3.6  $\Delta$ If the operation of soft starter or motor is abnormal or encounter fault, please stop the operation immediately and check the reason according to the actual condition;

6.3.7  $\Delta$ If "timeout of starting limited current", "operation overload" and other fault protections are reported during soft start, the motor temperature may be high at this time. It should be given sufficient cooling time before the motor is started again (generally more than 30 minutes), otherwise the motor may be damaged.

6.3.8  $\Delta$ After the soft starter is powered on, do not open the cover to avoid electrocution, and do not touch any control terminal and main circuit terminal.

### 6.4 Description of operation panel, supporting board and door

6.4.1 Figure 6.1a): Schematic diagram of operation panel.

6.4.2 Figure 6.1b): Dimension drawing of operation panel installation i.e. cabinet door cut-out. The operation panel can be directly installed on the cabinet door.

**NOTE: If the operation panel is directly installed on the cabinet door, the thickness of the cabinet door (including painting thickness) must be less than 2mm, otherwise it will be difficult to get embedded.**

6.4.3 Figure 6.2a): Schematic diagram of supporting board. The operation panel can be installed in the supporting board.

6.4.4 Figure 6.2b): Dimension drawing of supporting board installation i.e. cabinet door cut-out. The supporting board (including operation panel) can be installed on the cabinet door.

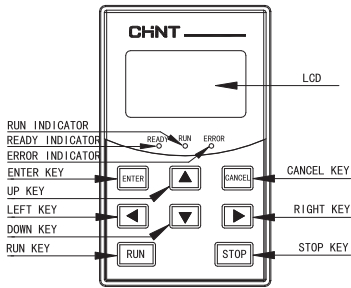

**Figure 6.1a) Schematic diagram of operation panel**

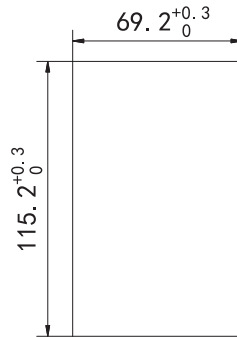

**Figure 6.1b) Figure of operation panel installation (cabinet door cut-out)**

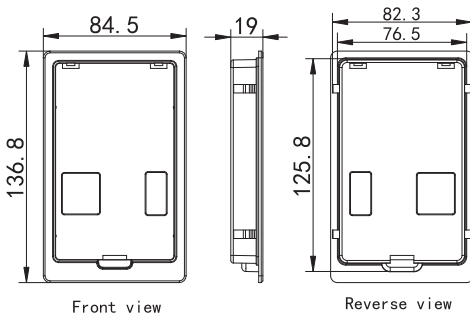

**Figure 6.2a) Schematic diagram of supporting board**

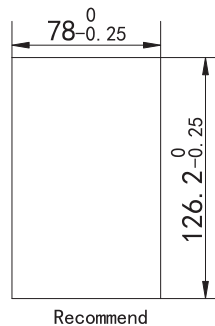

**Figure 6.2b) Figure of supporting board installation (cabinet door cut-out)**

The operation panel can be directly installed on the cabinet door, or it can also be installed to the supporting board first and then to the cabinet door. During the installation process, the operation panel should be taken out from the upper cover of the product and be installed on the cabinet door (it can be directly installed or through a supporting board). The extended outer lead is used to connect the operation panel and the cabinet door (the maximum length of the outer lead is 10m, and special customization is required when it exceeds 10m) .

6.4.5 Description of operation panel keys

RUN: It is for starting operation.

STOP: It is for stopping operation or fault reset.

ENTER: It is used to enter the parameter group menu, also to confirm and save the modified parameter data.

UP/DOWN: In menu selection, it is used to turn pages to display content; When setting specific data, it is used to increase or decrease the required modification parameters; In the main interface, it is used to switch each monitoring interface.

LEFT/RIGHT: When setting specific parameter values, it is used to select data setup; In the main interface, the right key is used to clear the fault information, and the left key is used to restore the parameters to the factory value.

CANCEL: It is used to return to the previous menu or to discard the parameter settings.

#### 6.4.6 Description of operation panel indicators

Indicators	Illustration
"READY" indicator	In the ready state, the "READY" indicator is normally on; In the countdown of starting state, the "READY" indicator flashes; When not in the above state, the "READY" indicator is off.
"RUN" indicator	In the operating state, the "RUN" indicator is normally on; Under the conditions of soft start, soft stop, braking, low-speed clockwise rotation and low-speed reverse rotation, the " RUN " indicator flashes; When not in the above state, the " RUN " indicator light is off.
"ERROR" indicator	In the fault state, the " ERROR " indicator is normally on; Under the alarm, the " ERROR " indicator flashes; When not in the above state, the " ERROR " indicator is off.

**NOTE:** The on time of LCD backlight is determined by the parameter F8.01 (automatic off time of LCD backlight).

#### 6.5 Function settings

Instructions mainly from restoring the parameter to the factory value, error fixing, fault record query and parameters settings, restoring the parameter to the factory value refer to fig 6.3a), error fixing refer to fig 6.3b), fault record query refer to fig 6.3c), parameters settings refer to fig 6.3d).

If no key is operated for more than 1 minute in the setting state, it will automatically exit the setting state.

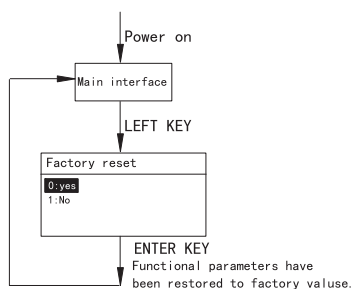

**Figure 6.3a) Restoring the parameter to the factory value**

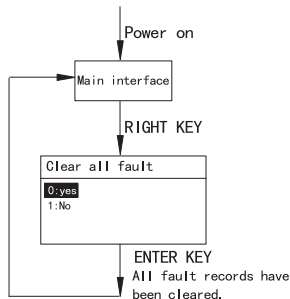

**Figure 6.3b) Error clear**



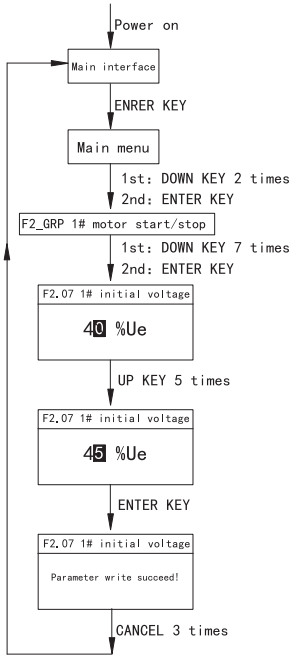

Figure 6.3c) Fault record query

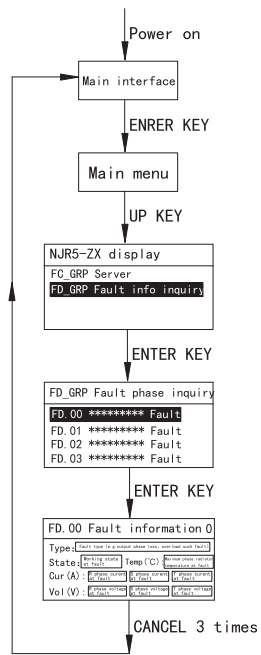

Figure 6.3d) Parameters settings

### 6.6 Fault log explained

When fault message shows up, enter the FD group and check the FD.00~FD.09 fault information. In the FD.00~FD.09 operation interface, press "Confirm" to enter the fault information grouping interface, which contains the fault type, the operating status before the fault, the maximum temperature of the product before the fault, the phase current at the time of the fault and the phase voltage value at the time of the fault. For details, check Figure 6.4.

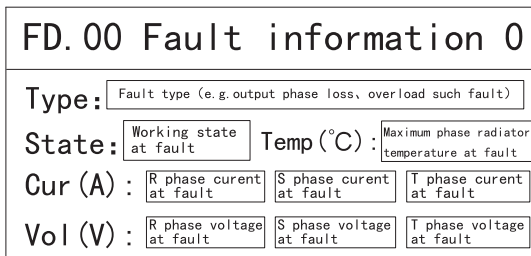

Figure 6.4 Fault log record

## 6.7 Definition and description of parameters

### 6.7.1 Explanation of unit/symbol (check table 6.1)

**Table 6.1 Explanation of unit/symbol**

Name of unit/symbol	Full name
V	Voltage unit: Volt
A	Current unit: Ampere
kW	Power unit: Kilowattage
kvar	Power unit: Kilovars
kVA	Power unit: KiloVoltage*Ampere
MWH	Power unit: MillionWattge*Hours
kWH	Power unit: KiloWattage*Hours
Hz	Frequency unit: Herz
kH	Time unit: Kilohours
H	Time unit: Hour
s	Time unit: Second
ms	Time unit: Millisecond
μs	Time unit: Microsecond
°C	Temperature unit: Celsius
Us	Rated voltage of control circuit of soft starter
Ue	Rated voltage of motor
In	Rated Current of soft starter
Ie	Rated current of motor
Te	Rated torque of motor
RPM	Speed of motor, Revolutions Per Minute
SS	"SS" is the abbreviation of soft starter
SCR	"SCR" is the abbreviation of thyristor

### 6.7.2 Description of parameters

The parameter table contains F0 group (Factory parameter group), F1 group (Start/Stop control group), F2 group (First motor start/stop group), F3 ( Second motor start/stop group), F4 group (Third motor start/stop group), F5 group (External controlled terminal input/output group), F6 group (Analog output group), F7 group (Protection parameter group), F8 group (Human-machine interface group), F9 group (Communication parameter group), FA group (Status information inquiry group), FB group (Enhancement group), FC group (Service group), FD group (Fault/alarm information inquiry group), a total of 14 functional groups, see Table 6.2 for details (We are not able to introduce F0 group since it is the manufacturer's parameter group).

**Note:** The function parameters can be modified only in the ready state or fault state; modification in other states is invalid.

**Table 6.2 Description of parameters**

Code	Content	Setting range	Default Value	Parameter details explained
<b>Group F1: Start/Stop control group</b>				
F1.00	Start/Stop channel	0: External ctrl terminal 1: Local panel 2: Remote communication 3: External + local 4: External + remote 5: Local + remote 6: Ext + local + remote 7: Forbit start	3: External + local	External ctrl terminal : Start or stop is realized by closing or opening the external control terminals RUN, STOP and COM. Local Panel : Start or stop through 485 communication with local operation panel. Remote communication : 485 communication with the upper computer through the external control terminals 485 +, 485 -. Different start/stop channel can be selected to perform the start or stop of the motor. <b>Note :</b> Starting is based on setting value. Stopping can only be conducted when receiving effective signal from external control terminal, local panel or remote communication, which is not related to F1.00 setting.

**Table 6.2 (Continued)**

Code	Content	Setting range	Default Value	Parameter details explained																																																																			
F1.01	Start delay	(1~999)s	1s	After receiving an effective start signal and a delay setting of F1.01, then the motor will start and gradually accelerate until it switches to online operation. When delay start happens, the 'Ready' LED on the panel will flashes until the end of delay start.																																																																			
F1.02	Sequence start num	0: One motor 1: Two motors 2: Three motors	0: One motor	0 : soft starter only start one motor. 1 : soft starter sequently start 2 motors (parameters of those 2 motors could be set by F2 and F3). 2 : soft starter sequently start 3 motors (parameters of those 3 motors could be set by F2, F3 and F4).																																																																			
F1.03	Strenth of low fwd.	(10~100)%le	40%le	Motor will low speed run based on strength, speed or rotation direction set by F1.03-F1.06 when parameter F5.01 or F5.02 set as 'Low forward' or 'Low reverse' and external control terminal IN1 or IN2 closed with COM. <b>Note1 : If motor speed doesn' t meet the requirement, you can tune up F1.03 or F1.05.</b> <b>Note2 : Please stop using this function immediately when motor drastically vibrate.</b>																																																																			
F1.04	Speed of low fwd.	0: 15% rated speed 1: 7% rated speed	0:15% rated speed																																																																				
F1.05	Strenth of low rev.	(10~100)%le	40%le																																																																				
F1.06	Speed of low rev	0: 20% rated speed 1: 10% rated speed	0:20% rated speed																																																																				
<b>Group F2 : 1st motor start/stop group</b> <b>Note : Factory default parameter effectiveness is only applied on F2, not F3 and F4.</b>																																																																							
F2.00	1# load type sel	0: No application 1: Deep-well pump 2: Centrifugal pump 3: Hydraulic pump 4: Axial flow fan 5: Centrifugal fan 6: Mixer 7: Compressor 8: Crusher 9: Ball mill 10: Belt conveyer 11: Propeller	0: No application	0 : default settings ; <b>Not 0</b> : Different loads have different settings with parameter down below:																																																																			
				<table border="1"> <thead> <tr> <th>No</th> <th>Load type</th> <th>Start mode</th> <th>Current limiting ratio</th> <th>Default voltage</th> <th>Soft start time factor</th> </tr> </thead> <tbody> <tr> <td>1</td> <td>deep-well pump</td> <td rowspan="7">Normal voltage mode</td> <td>400%le</td> <td>50%</td> <td>6s</td> </tr> <tr> <td>2</td> <td>centrifugal pump</td> <td>350% le</td> <td>40%</td> <td>10s</td> </tr> <tr> <td>3</td> <td>hydraulic pump</td> <td>350% le</td> <td>40%</td> <td>10s</td> </tr> <tr> <td>4</td> <td>axial flow fan</td> <td>350% le</td> <td>40%</td> <td>10s</td> </tr> <tr> <td>5</td> <td>centrifugal fan</td> <td>350% le</td> <td>40%</td> <td>10s</td> </tr> <tr> <td>6</td> <td>mixer</td> <td>400% le</td> <td>50%</td> <td>10s</td> </tr> <tr> <td>7</td> <td>compressor</td> <td>300% le</td> <td>40%</td> <td>10s</td> </tr> <tr> <td>8</td> <td>crusher</td> <td>Normal current mode</td> <td>350% le</td> <td>70%</td> <td>4s</td> </tr> <tr> <td>9</td> <td>ball mill</td> <td>450% le</td> <td>70%</td> <td>4s</td> </tr> <tr> <td>10</td> <td>belt conveyer</td> <td rowspan="2">Linear torque mode</td> <td>300% le</td> <td>40%</td> <td>10s</td> </tr> <tr> <td>11</td> <td>propeller</td> <td>300% le</td> <td>40%</td> <td>10s</td> </tr> </tbody> </table>				No	Load type	Start mode	Current limiting ratio	Default voltage	Soft start time factor	1	deep-well pump	Normal voltage mode	400%le	50%	6s	2	centrifugal pump	350% le	40%	10s	3	hydraulic pump	350% le	40%	10s	4	axial flow fan	350% le	40%	10s	5	centrifugal fan	350% le	40%	10s	6	mixer	400% le	50%	10s	7	compressor	300% le	40%	10s	8	crusher	Normal current mode	350% le	70%	4s	9	ball mill	450% le	70%	4s	10	belt conveyer	Linear torque mode	300% le	40%	10s	11	propeller	300% le	40%	10s
				No	Load type	Start mode	Current limiting ratio	Default voltage	Soft start time factor																																																														
				1	deep-well pump	Normal voltage mode	400%le	50%	6s																																																														
				2	centrifugal pump		350% le	40%	10s																																																														
				3	hydraulic pump		350% le	40%	10s																																																														
				4	axial flow fan		350% le	40%	10s																																																														
				5	centrifugal fan		350% le	40%	10s																																																														
				6	mixer		400% le	50%	10s																																																														
				7	compressor		300% le	40%	10s																																																														
				8	crusher	Normal current mode	350% le	70%	4s																																																														
				9	ball mill	450% le	70%	4s																																																															
10	belt conveyer	Linear torque mode	300% le	40%	10s																																																																		
11	propeller		300% le	40%	10s																																																																		
<b>Note : Table is only for reference, you should adjust it by the loads, if the transformer capacity is small, the current limit multiplier should gradually increase from a smaller value to the appropriate value, both to ensure that the motor can start up and to ensure that the front-end circuit breaker does not trip.</b>																																																																							
F2.01	1# rated current	(1~1600)A	Actual motor rated current	The rated current of the first motor in the specific factory is shown in Table 1.1a) to Table 1.1e) for the rated current of the adapted motor.																																																																			

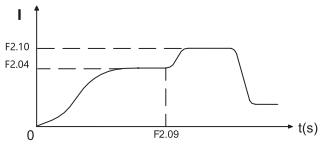
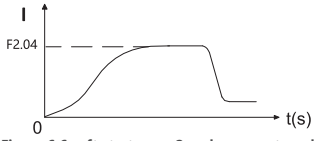
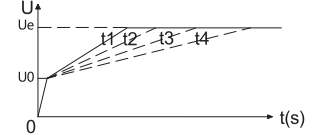
Code	Content	Setting range	Default Value	Parameter details explained
F2.02	1# start mode	0: Normal current mode 1: Enhanced current mode 2: Normal voltage mode 3: Enhanced voltage mode 4: Linear torque mode 5: Square torque mode 6: Frequency division mode	2: Normal voltage mode	<p><b>1. Instruction of normal current mode and enhanced current mode</b></p> <p><b>1.1</b> This starting mode is more suitable for grid in large fluctuations of frequency (the generator is running at frequency 35 to 60)</p> <p><b>1.2</b> This start mode has strong starting capability and is suitable for heavy load application, its enhanced current mode is stronger than normal mode.</p> <p><b>1.3</b> Performance and effectiveness under this start mode are only associated with the setting value of F2.04, F2.09 and F2.10. The larger of F2.04 setting value is, the starting strength is more powerful, starting time is less, but it needs higher transformer capacity.</p> <p><b>1.4</b> Figure 6.5 for starting wave when 2<sup>nd</sup> current limit functional is enable, figure 6.6 when it's not enable,</p>  <p><b>Figure 6.5 soft start wave 1 under current mode</b></p>  <p><b>Figure 6.6 soft start wave 2 under current mode</b></p> <p><b>2. Instruction of normal voltage mode and enhanced voltage mode</b></p> <p><b>2.1</b> This starting mode is more suitable for grid in small fluctuations of frequency ( frequency at <math>\pm 2\text{Hz}</math> )</p> <p><b>2.2</b> The starting ability of enhanced voltage mode is stronger than it is in normal voltage mode.</p> <p><b>2.3</b> The performance or effectiveness of soft starter under this starting mode is not only related to the settings of F2.04, F2.09 and F2.10, but also the settings of F2.07 and F2.08. What's more, the larger the current limit multiple is, the stronger the starting will be, the shorter the starting time will be; The more default voltage it set, the stronger the starting will be, the shorter the starting time will be; The lower the soft start time factor is, the stronger the starting will be, the shorter the starting time will be.</p> <p><b>2.4</b> Figure 6.7 for the wave of this starting mode.</p>  <p><b>Figure 6.7 Wave in voltage mode</b></p> <p>In Figure 6.7, U0 stand for default voltage. The larger the F2.07 is, the larger the starting default torque is; t1、t2、t3 and t4 stands for the setting of F2.08 (t1&lt;t2&lt;t3&lt;t4), The less it is, the faster the output voltage and motor will accelerate.</p> <p><b>Note : The starting current is also limited under voltage mode.</b></p>

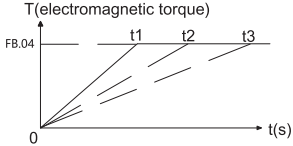
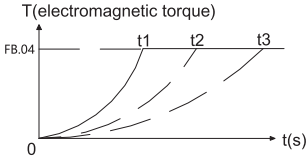
Code	Content	Setting range	Default Value	Parameter details explained
				<p><b>3. Instruction of linear torque mode and square torque mode.</b></p> <p><b>3.1</b> This starting mode is more suitable for applications that require high smoothness when starting the load.</p> <p><b>3.2</b> This starting mode is more suitable for grid in small fluctuations of frequency ( frequency at <math>\pm 2\text{Hz}</math> ).</p> <p><b>3.3</b> The performance or effectiveness of soft starter under this starting mode is related to not only the settings of F2.09 and F2.10, but also the settings of F2.08 and FB.04.</p> <p><b>3.4</b> Figure 6.8 for soft starter wave under linear torque mode and figure 6.9 for wave under square torque mode.</p>  <p><b>Figure 6.8 soft starter wave under linear torque mode</b></p> <p>In figure 6.8, The output electromagnetic torque of the soft starter increases linearly with time during the soft start process. T1, t2 and t3 stand for the setting of F2.08 ( <math>t1 &lt; t2 &lt; t3</math> ). When soft starter reach the setting of F2.08, output electromagnetic torque will reach the value of FB.04.</p>  <p><b>Figure 6.9 wave under square torque mode</b></p> <p>In figure 6.8, The output electromagnetic torque of the soft starter increases bu square index with time during the soft start process. T1, t2 and t3 stand for the setting of F2.08 ( <math>t1 &lt; t2 &lt; t3</math> ). When soft starter reach the setting of F2.08, output electromagnetic torque will reach the value of FB.04.</p> <p><b>Note :</b> The torque mode has a double limit function, i.e. it is limited by both the current limit multiple and the torque limitation.</p> <p><b>4 Instruction of frequency dividing mode</b></p> <p><b>4.1</b> This starting mode is more suitable for grid in small fluctuations of frequency ( frequency at <math>\pm 2\text{Hz}</math> ).</p> <p><b>4.2</b> The soft start starts at 1/4 grid frequency in the early stages and at grid frequency and in normal voltage mode in the later stages.</p>
F2.03	1# stop mode	0: Freedom stop 1: Brake stop 2: Voltage ramp soft stop	0: Freedom stop	<p>Selection of 1<sup>st</sup> motor stop mode</p> <p>0: Freedom stop</p> <p>1 : Brake stop. Braking time is determined by F2.13, since current presents on only two phrases when braking. The absence of the current on the 3<sup>rd</sup> phrase will cause three-phase imbalance in the grid when the grid capacity is insufficient. So be cautious.</p> <p>2 : Voltage ramp soft stop. It is the reverse process of soft start. The shutting down time is determined by F2.11. The current limit multiple of soft stop is 0.5 time of F2.04 setting value.</p>

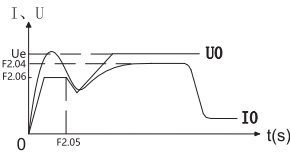
Code	Content	Setting range	Default Value	Parameter details explained
F2.04	1# limit I. times	(50~500)%Ie	350%Ie	When the 1 <sup>st</sup> motor soft start current reaches the current limit value, the output voltage remains stable until the current value drops below the current limit value, then the boosting process will continue.
F2.05	1# jump time	(0.0~2.0)s	0.0s	0 : 1 <sup>st</sup> motor will not suddenly raise when it is starting Not 0 : 1 <sup>st</sup> motor will suddenly raise when it is starting.
F2.06	1# jump voltage	(50~100)%Ue	80%Ue	During the sudden-raise, charge voltage to 1 <sup>st</sup> motor.
F2.07	1# initial voltage	(30~70)%Ue	40%Ue	Figure 6.10 for sudden-raise wave chart under current mode. In the figure 6.10, U0 is output voltage and I0 is output current.  <p style="text-align: center;">Figure 6.10 sudden-raise start wave</p>
F2.08	1# start time factor	(2~60)s	10s	When the first motor receives the start signal, the voltage or torque at the motor input will gradually increase. <b>Note :</b> The soft start time factor is not the total time of the whole starting process of the soft starter, the larger the setting value the slower the output current and voltage rise, and vice versa the faster the output current and voltage rise.
F2.09	1# 2nd limit I. time	(0~60)s	0s	0 : Ineffectiveness of 1 <sup>st</sup> motor 2 <sup>nd</sup> current limiting. Not 0 : Starting time of Ineffectiveness of 1 <sup>st</sup> motor 2 <sup>nd</sup> current limiting
F2.10	1# 2nd limit I.times	F2.04~500%Ie	450%Ie	2 <sup>nd</sup> motor 2 <sup>nd</sup> current limiting value.
F2.11	1# sft stp T. factor	(2~60)s	2s	When the first motor receives a stop signal, the voltage or torque at the motor input is gradually reduced to stop the motor. It is valid when function parameter F2.03 is set to '2: Voltage ramp soft stop' . <b>Note :</b> The soft shutdown time factor is not the total time of the entire soft shutdown process of the soft starter, the larger the setting value the longer the soft stop process, the slower the output voltage drop, and vice versa the shorter the soft shutdown process, the faster the output voltage shutdown.
F2.12	1# soft stop end V.	(20~80)%Ue	30%Ue	The voltage level at the end of the first motor stop is valid when function parameter F2.03 is set to '2: Voltage ramp soft stop' .
F2.13	1# brake stop time	(2~60)s	10s	The whole braking shutdown time is valid when the function parameter F2.03 is set to '1: Brake stop' , when the 1 <sup>st</sup> motor receives the stop signal, DC current is input to the motor, so that the motor gradually decelerates and shutdown.
F2.14	1# brake stp strenth	(20~100)%	40%	The higher the braking intensity, the higher the 1 <sup>st</sup> braking current and the better the shutdown effect. <b>Note:</b> The greater the braking strength, the better the braking effect, the mechanical vibration may become larger, so be careful when modifying.
<b>Group F3 : 2<sup>nd</sup> motor start/stop group</b> <b>Note :</b> F3 parameter is effective only when the 2 <sup>nd</sup> motor is selected. ( check instructions of F1.02, F5.01 and F5.02 for more details)				

Code	Content	Setting range	Default Value	Parameter details explained
F3.00	2# load type sel	0: No application 1: Deep-well pump 2: Centrifugal pump 3: Hydraulic pump 4: Axial flow fan 5: Centrifugal fan 6: Mixer 7: Compressor 8: Crusher 9: Ball mill 10: Belt conveyer 11: Propeller	0: No application	Function works exactly like F2.00.
F3.01	2# rated current	(1~1600)A	Actual motor rated current	Rated current of 2 <sup>nd</sup> motor
F3.02	2# start mode	0: Normal current mode 1: Enhanced current mode 2: Normal voltage mode 3: Enhanced voltage mode 4: Linear torque mode 5: Square torque mode 6: Frequency division mode	2: Normal voltage mode	Function works exactly like F2.02.
F3.03	2# stop mode	0: Freedom stop 1: Brake stop 2: Voltage ramp soft stop	0: Freedom stop	Function works exactly like F2.03.
F3.04	2# limit l. times	(50~500)%le	350%le	Function works exactly like F2.04.
F3.05	2# jump time	(0.0~2.0)s	0.0s	Function works exactly like F2.05.
F3.06	2# jump voltage	(50~100)%Ue	80%Ue	Function works exactly like F2.06.
F3.07	2# initial voltage	(30~70)%Ue	40%Ue	Function works exactly like F2.07.
F3.08	2# start time factor	(2~60)s	10s	Function works exactly like F2.08.
F3.09	2# 2nd limit l. time	(0~60)s	0s	Function works exactly like F2.09.
F3.10	2# 2nd limit l.times	F2.04~500%le	450%le	Function works exactly like F2.10.
F3.11	2# sft stp T. factor	(2~60)s	2s	Function works exactly like F2.11.
F3.12	2# soft stop end V.	(20~80)%Ue	30%Ue	Function works exactly like F2.12.
F3.13	2# brake stop time	(2~60)s	10s	Function works exactly like F2.13.
F3.14	2# brake stp strenth	(20~100)%	40%	Function works exactly like F2.14.
<b>Group F4 : 3<sup>rd</sup> motor start/stop group</b>				
<b>Note : F4 parameter is effective only when the 3<sup>rd</sup> motor is selected. ( check instructions of F1.02, F5.01 and F5.02 for more details)</b>				

Code	Content	Setting range	Default Value	Parameter details explained
F4.00	3# load type sel	0: No application 1: Deep-well pump 2: Centrifugal pump 3: Hydraulic pump 4: Axial flow fan 5: Centrifugal fan 6: Mixer 7: Compressor 8: Crusher 9: Ball mill 10: Belt conveyer 11: Propeller	0: No application	Function works exactly like F2.00.
F4.01	3# rated current	(1~1600)A	Actual motor rated current	3# motor rated current
F4.02	3# start mode	0: Normal current mode 1: Enhanced current mode 2: Normal voltage mode 3: Enhanced voltage mode 4: Linear torque mode 5: Square torque mode 6: Frequency division mode	2: Normal voltage mode	Function works exactly like F2.02
F4.03	3# stop mode	0: Freedom stop 1: Brake stop 2: Voltage ramp soft stop	0: Freedom stop	Function works exactly like F2.03.
F4.04	3# limit I. times	(50~500)%le	350%le	Function works exactly like F2.04.
F4.05	3# jump time	(0.0~2.0)s	0.0s	Function works exactly like F2.05.
F4.06	3# jump voltage	(50~100)%Ue	80%Ue	Function works exactly like F2.06.
F4.07	3# initial voltage	(30~70)%Ue	40%Ue	Function works exactly like F2.07.
F4.08	3# start time factor	(2~60)s	10s	Function works exactly like F2.08.
F4.09	3# 2nd limit I. time	(0~60)s	0s	Function works exactly like F2.09.
F4.10	3# 2nd limit I.times	F2.04~500%le	450%le	Function works exactly like F2.10.
F4.11	3# sft stp T. factor	(2~60)s	2s	Function works exactly like F2.11.
F4.12	3# soft stop end V.	(20~80)%Ue	30%Ue	Function works exactly like F2.12.
F4.13	3# brake stop time	(2~60)s	10s	Function works exactly like F2.13.
F4.14	3# brake stp strenth	(20~100)%	40%	Function works exactly like F2.14.
<b>Group F5 : External terminal group</b>				
F5.00	Relay valid status	0x0000~0x0011	0x0000	<p><b>Unit:</b> It is used to set the effectiveness of output relay K3. When it is 0, it indicates that terminals K3A and K3b are in an effective state when they are closed; When it is 1, it indicates that it is in an effective state when terminals K3A and K3b are disconnected;</p> <p><b>Ten-bit:</b> It is used to set the effectiveness of output relay K2. When it is 0, it indicates that it is in an effective state when terminals K2A and K2B are closed; When it is 1, it indicates that the terminal K2A and K2B are in an effective state when they are disconnected; <b>NOTE: They are hexadecimal numbers.</b></p>



Code	Content	Setting range	Default Value	Parameter details explained
F5.01	In1 function select	0: None 1: External fault 2: 2# start/stop Para valid 3: 3# start/stop Para valid 4: Fault reset 5: Low forward 6: Low reverse	1: External fault	<p>COM is set as a reference, 0: The function of input terminals IN1 and IN2 is invalid. 1: When it is effective that input terminal IN1 or IN2 is closed with COM, 'External failure' will be reported. 2: When it is effective that input terminal IN1 or IN2 is closed with COM, the 2<sup>nd</sup> motor will be selected and F3 setting value is valid. 3: When it is effective that input terminal IN1 or IN2 is closed with COM, the 3<sup>rd</sup> motor will be selected and F4 setting value is valid. 4 When it is effective that input terminal IN1 or IN2 is closed with COM, the fault meeting the conditions will be reseted. 5: When it is effective that input terminal IN1 or IN2 is closed with COM, low-speed clockwise rotation will be performed. 6 When it is effective that input terminal IN1 or IN2 is closed with COM, low-speed reverse rotation will be performed.</p> <p><b>Example 1 : How to realize low-speed clockwise rotation with IN1 terminal.</b></p> <p>During preparation, please set F5.01 to ' 5 : Low-speed clockwise enablement ', and then close the terminal IN1 and COM effectively. The motor will keep low-speed clockwise rotation during this period and will stop after the disconnection of IN1 and COM.</p> <p><b>Example 2 : How to realize soft start of two motors one by one</b></p> <p>The peripheral configuration circuits refer to Appendix B. 2.1 and B. 2.2. During preparation, F2 and F3 should be set according to the nameplate of 1<sup>st</sup> and 2<sup>nd</sup> motor and the field conditions. After that, F1.02 should be set to '1: 2 motors' and F5.01 should be set to '2: Effectiveness of the 2<sup>nd</sup> motor start and stop parameter' . Finally, please press the starting button SB2 to start the first motor, and then press the starting button SB4 after the first motor is soft started.</p> <p><b>Example 3 : How to realize soft start of three motors one by one</b></p> <p>The peripheral configuration circuits refer to Appendix B. 2.3 and B. 2.4. During preparation, F2, F3 and F4 should be set according to the nameplate of 1<sup>st</sup>, 2<sup>nd</sup> and 3<sup>rd</sup> motor and the field conditions. After that, F1.02 should be set to '2: 3 motors' , F5.01 should be set to '2: Effectiveness of the 2nd motor start and stop parameter' and F5.02 should be set to '3: Effectiveness of the 3<sup>rd</sup> motor start and stop parameter' . Finally, please press the starting button SB2 to start the first motor. After the first motor is soft started, press the starting button SB4 to begin the soft start of the second motor. After the second motor is soft started, press the starting button SB6 to begin the soft start of the third motor.</p> <p><b>Note 1: In Example 2 or Example 3, the shutdown modes F2.03, F3.03 and F4.03 must be set to "0: free shutdown".</b> <b>Note 2: Effective close means that the IN1 or IN2 terminal signal is detected to change from disconnection (the disconnect time is longer than F5.04 or F5.06 setting value) to close (the F5.03 or F5.05 setting value).</b></p>
F5.02	In2 function select		4: Fault reset	
F5.03	In1 close delay	(1~200)ms	50ms	It is effective that IN1 terminal close time is longer than this setting value.
F5.04	In1 open delay	(1~200)ms	50ms	It is effective that IN1 terminal disconnect time is longer than this setting value.
F5.05	In2 close delay	(1~200)ms	50ms	It is effective that IN2 terminal close time is longer than this setting value.

Code	Content	Setting range	Default Value	Parameter details explained
F5.06	In2 open delay	(1~200)ms	50ms	It is effective that IN2 terminal disconnect time is longer than this setting value.
F5.07	RUN close delay	(1~20000)ms	200ms	It is effective that RUN terminal close time is longer than this setting value.
F5.08	RUN open delay	(1~20000)ms	100ms	It is effective that RUN terminal disconnect time is longer than this setting value.
F5.09	STOP close delay	(1~20000)ms	200ms	It is effective that STOP terminal close time is longer than this setting value.
F5.10	STOP open delay	(1~20000)ms	100ms	It is effective that STOP terminal disconnect time is longer than this setting value.
F5.11	EMS close delay	(1~20000)ms	100ms	It is effective that EMS terminal close time is longer than this setting value.
F5.12	EMS open delay	(1~200)ms	100ms	It is effective that EMS terminal disconnect time is longer than this setting value.
F5.13	K2 Relay output sel	0: Ready status 1: Soft start status 2: Onlin/bypass status 3: Soft stop status 4: Fault status 5: Brake status 6: Low fwd status 7: Low rev status	2: Onlin/bypass status	State relay K2 output is determined by parameters F5.00 and F5.13. When the ten-bit of F5.00 is 0, it means that the terminals K2A and K2B are closed, which is effective; When the ten-bit of F5.00 is 1, it means that the terminals K2A and K2B are disconnected, which is effective. <b>Examples:</b> When the ten-bit of F5.00 is 0, F5.13 is '2: Online/bypass state', K2A and K2B terminals are closed when the soft starter is under online/bypass operation state, and are disconnected when it is under other operation state. When the ten-bit of F5.00 is 1, F5.13 is '2: Online/bypass state', K2A and K2B terminals are disconnected when the soft starter is under online/bypass operation state, and are closed when it is under other operation state
F5.14	K3 Relay output sel	0: Any fault/alarm 1: Over load 2: Lock rotor/short 3: Limit I, timeout 4: Unbalance of I. 5: Outp phase loss 6: Input phase loss 7: Frequency wrong 8: SCR short 9: SS over hot 10: Motor over hot 11: Bypass switch fit 12: Main circuit OV. 13: Main circuit UV. 14: Ctrl circuit OV. 15: Ctrl circuit UV. 16: CPU run timeout 17: EMS opened fault 18: Too many starts 19: Too long start tim 20: Parameter wrong 21: External fault 22: Communi timeout 23: SS OH. alarm 24: Under load alarm	0: Any fault/alarm	The output function of fault relay K3 is determined by parameters F5.00 and F5.14. When the unit of F5.00 is 0, it means that the terminals K3A and K3B are closed, which is effective; When the unit of F5.00 is 1, it means that the terminals K3A and K3B are disconnected, which is effective. <b>Examples:</b> When the unit of F5.00 is 0, F5.14 is '0: Any fault/alarm', K3A and K3B terminals are closed when the soft starter has any fault or alarm, and are disconnected when there is no fault or alarm; When the unit of F5.00 is 1, F5.14 is '0: Any fault/alarm', K2A and K2B terminals are disconnected when the soft starter has any fault or alarm, and are closed when there is no fault or alarm.
<b>Group F6 : Analog output Group</b>				

Code	Content	Setting range	Default Value	Parameter details explained																																																															
F6.00	Analog output Type	0: 4mA~20mA 1: 0mA~20mA 2: 2mA~10mA 3: 0mA~10mA	0: 4mA~20mA	See table 6.3 for analog output current.																																																															
				<b>Table 6.3 Analog output current</b>																																																															
				<table border="1"> <thead> <tr> <th>Analog output current (mA)</th> <th>F6.00 Analog output type</th> <th>F6.01 Analog output function</th> </tr> </thead> <tbody> <tr> <td>4+3.2×I+Ie</td> <td rowspan="7">0 : 4mA~20mA</td> <td>0:Motor I<sub>max</sub>=500%I<sub>e</sub></td> </tr> <tr> <td>4+8×I+Ie</td> <td>1:Motor I<sub>max</sub>=200%I<sub>e</sub></td> </tr> <tr> <td>4+16×I+Ie</td> <td>2:Motor I<sub>max</sub>=100%I<sub>e</sub></td> </tr> <tr> <td>4+16×U+1000</td> <td>3: Main circuit voltage [V]</td> </tr> <tr> <td>4+16×C+100</td> <td>4: SS temperature [°C]</td> </tr> <tr> <td>4+16×λ</td> <td>5: Power factor</td> </tr> <tr> <td>4+16×T+300</td> <td>6: Electromagnetic torque [100%]</td> </tr> <tr> <td>4×I+Ie</td> <td rowspan="7">1 : 0mA~20mA</td> <td>0:Motor I<sub>max</sub>=500%I<sub>e</sub></td> </tr> <tr> <td>10×I+Ie</td> <td>1:Motor I<sub>max</sub>=200%I<sub>e</sub></td> </tr> <tr> <td>20×I+Ie</td> <td>2:Motor I<sub>max</sub>=100%I<sub>e</sub></td> </tr> <tr> <td>20×U+1000</td> <td>3: Main circuit voltage [V]</td> </tr> <tr> <td>20×C+100</td> <td>4: SS temperature [°C]</td> </tr> <tr> <td>20×λ</td> <td>5: Power factor</td> </tr> <tr> <td>20×T+300</td> <td>6: Electromagnetic torque [100%]</td> </tr> <tr> <td>2+1.6×I+Ie</td> <td rowspan="7">2 : 2mA~10mA</td> <td>0:Motor I<sub>max</sub>=500%I<sub>e</sub></td> </tr> <tr> <td>2+4×I+Ie</td> <td>1:Motor I<sub>max</sub>=200%I<sub>e</sub></td> </tr> <tr> <td>2+8×I+Ie</td> <td>2:Motor I<sub>max</sub>=100%I<sub>e</sub></td> </tr> <tr> <td>2+8×U+1000</td> <td>3: Main circuit voltage [V]</td> </tr> <tr> <td>2+8×C+100</td> <td>4: SS temperature [°C]</td> </tr> <tr> <td>2+8×λ</td> <td>5: Power factor</td> </tr> <tr> <td>2+8×T+300</td> <td>6: Electromagnetic torque [100%]</td> </tr> <tr> <td>2×I+Ie</td> <td rowspan="7">3 : 0mA~10mA</td> <td>0:Motor I<sub>max</sub>=500%I<sub>e</sub></td> </tr> <tr> <td>5×I+Ie</td> <td>1:Motor I<sub>max</sub>=200%I<sub>e</sub></td> </tr> <tr> <td>10×I+Ie</td> <td>2:Motor I<sub>max</sub>=100%I<sub>e</sub></td> </tr> <tr> <td>10×U+1000</td> <td>3: Main circuit voltage [V]</td> </tr> <tr> <td>10×C+100</td> <td>4: SS temperature [°C]</td> </tr> <tr> <td>10×λ</td> <td>5: Power factor</td> </tr> <tr> <td>10×T+300</td> <td>6: Electromagnetic torque [100%]</td> </tr> </tbody> </table>	Analog output current (mA)	F6.00 Analog output type	F6.01 Analog output function	4+3.2×I+Ie	0 : 4mA~20mA	0:Motor I <sub>max</sub> =500%I <sub>e</sub>	4+8×I+Ie	1:Motor I <sub>max</sub> =200%I <sub>e</sub>	4+16×I+Ie	2:Motor I <sub>max</sub> =100%I <sub>e</sub>	4+16×U+1000	3: Main circuit voltage [V]	4+16×C+100	4: SS temperature [°C]	4+16×λ	5: Power factor	4+16×T+300	6: Electromagnetic torque [100%]	4×I+Ie	1 : 0mA~20mA	0:Motor I <sub>max</sub> =500%I <sub>e</sub>	10×I+Ie	1:Motor I <sub>max</sub> =200%I <sub>e</sub>	20×I+Ie	2:Motor I <sub>max</sub> =100%I <sub>e</sub>	20×U+1000	3: Main circuit voltage [V]	20×C+100	4: SS temperature [°C]	20×λ	5: Power factor	20×T+300	6: Electromagnetic torque [100%]	2+1.6×I+Ie	2 : 2mA~10mA	0:Motor I <sub>max</sub> =500%I <sub>e</sub>	2+4×I+Ie	1:Motor I <sub>max</sub> =200%I <sub>e</sub>	2+8×I+Ie	2:Motor I <sub>max</sub> =100%I <sub>e</sub>	2+8×U+1000	3: Main circuit voltage [V]	2+8×C+100	4: SS temperature [°C]	2+8×λ	5: Power factor	2+8×T+300	6: Electromagnetic torque [100%]	2×I+Ie	3 : 0mA~10mA	0:Motor I <sub>max</sub> =500%I <sub>e</sub>	5×I+Ie	1:Motor I <sub>max</sub> =200%I <sub>e</sub>	10×I+Ie	2:Motor I <sub>max</sub> =100%I <sub>e</sub>	10×U+1000	3: Main circuit voltage [V]	10×C+100	4: SS temperature [°C]	10×λ	5: Power factor	10×T+300	6: Electromagnetic torque [100%]
				Analog output current (mA)	F6.00 Analog output type	F6.01 Analog output function																																																													
				4+3.2×I+Ie	0 : 4mA~20mA	0:Motor I <sub>max</sub> =500%I <sub>e</sub>																																																													
				4+8×I+Ie		1:Motor I <sub>max</sub> =200%I <sub>e</sub>																																																													
				4+16×I+Ie		2:Motor I <sub>max</sub> =100%I <sub>e</sub>																																																													
				4+16×U+1000		3: Main circuit voltage [V]																																																													
				4+16×C+100		4: SS temperature [°C]																																																													
				4+16×λ		5: Power factor																																																													
				4+16×T+300		6: Electromagnetic torque [100%]																																																													
				4×I+Ie	1 : 0mA~20mA	0:Motor I <sub>max</sub> =500%I <sub>e</sub>																																																													
				10×I+Ie		1:Motor I <sub>max</sub> =200%I <sub>e</sub>																																																													
				20×I+Ie		2:Motor I <sub>max</sub> =100%I <sub>e</sub>																																																													
				20×U+1000		3: Main circuit voltage [V]																																																													
				20×C+100		4: SS temperature [°C]																																																													
				20×λ		5: Power factor																																																													
				20×T+300		6: Electromagnetic torque [100%]																																																													
				2+1.6×I+Ie	2 : 2mA~10mA	0:Motor I <sub>max</sub> =500%I <sub>e</sub>																																																													
				2+4×I+Ie		1:Motor I <sub>max</sub> =200%I <sub>e</sub>																																																													
				2+8×I+Ie		2:Motor I <sub>max</sub> =100%I <sub>e</sub>																																																													
				2+8×U+1000		3: Main circuit voltage [V]																																																													
				2+8×C+100		4: SS temperature [°C]																																																													
				2+8×λ		5: Power factor																																																													
				2+8×T+300		6: Electromagnetic torque [100%]																																																													
				2×I+Ie	3 : 0mA~10mA	0:Motor I <sub>max</sub> =500%I <sub>e</sub>																																																													
				5×I+Ie		1:Motor I <sub>max</sub> =200%I <sub>e</sub>																																																													
				10×I+Ie		2:Motor I <sub>max</sub> =100%I <sub>e</sub>																																																													
				10×U+1000		3: Main circuit voltage [V]																																																													
				10×C+100		4: SS temperature [°C]																																																													
				10×λ		5: Power factor																																																													
				10×T+300		6: Electromagnetic torque [100%]																																																													
								<p><b>Note 1:</b> Analog output current refers to the output current of terminal AO and forms a current loop with terminal GND,with unit mA.</p> <p><b>Note 2:</b> When analog output voltage is required, please parallel a 250Ω resistor between terminals AO and GND.</p> <p><b>Examples:</b></p> <p>When F6.00 setting is '0 : 4mA~20mA' , F6.01 setting is '1 : Motor I<sub>max</sub>=200%I<sub>e</sub>' , if the current is 1 times the rated current of the motor, current between terminals AO and GND in Analog Output = 4+16×1+2 = 12mA.</p>																																																											

Code	Content	Setting range	Default Value	Parameter details explained
F6.01	Analog output Func	0: Motor I <sub>max</sub> =500%I <sub>e</sub> 1: Motor I <sub>max</sub> =200%I <sub>e</sub> 2: Motor I <sub>max</sub> =100%I <sub>e</sub> 3: Main circuit voltage[V] 4: SS temperature [°C] 5: Power factor 6: Electromagnetic tor [100%]	1: Motor I <sub>max</sub> =200%I <sub>e</sub>	<p>'0' : The maximum value setting of F6.00 is 5 times the rated motor current, and the minimum is 0A.</p> <p>'1' : The maximum value setting of F6.00 is 2 times the rated motor current, and the minimum is 0A.</p> <p>'2' : The maximum value setting of F6.00 is 1 time the rated motor current, and the minimum is 0A.</p> <p>'3' : The maximum value corresponds to setting of F6.00 when the main circuit voltage is AC1000 V, and the minimum corresponds when it is 0V.</p> <p>'4' : The maximum value corresponds to setting of F6.00 when the soft starter temperature is 100 °C, and the minimum corresponds when it is 0 °C.</p> <p>'5' : The maximum value corresponds to setting of F6.00 when the power factor is 1.0, and the minimum corresponds when it is 0.</p> <p>'6' : The maximum value corresponds to setting of F6.00 when the electromagnetic torque / motor rated torque = 300 % , and the minimum corresponds when it is 0 %.</p>
<b>Group F7 : Protection parameters group</b>				
F7.00	OL.protect grade	0: level 2 1: level 10A 2: level 10 3: level 20 4: level 30	2: level 10	When setting the overload protection level of motor, the larger the overload level setting is, the longer the time to report ' Limit I. timeout' will be.
F7.01	OL.hot accumulatel	0~5	0	<p>'0' represents that overload thermal integral ( I<sub>2t</sub> ) is accumulated.</p> <p>'1' represents that the overload thermal integral is not accumulated, when the load current is less than 1.1 times the rated motor current, the current thermal integral will be reset.</p> <p>'2' represents that the overload thermal integral is not accumulated, when the load current is less than 1.2 times the rated motor current, the current thermal integral will be reset.</p> <p>'3' represents that the overload thermal integral is not accumulated, when the load current is less than 1.3 times the rated motor current, the current thermal integral will be reset.</p> <p>'4' represents that the overload thermal integral is not accumulated, when the load current is less than 1.4 times the rated motor current, the current thermal integral will be reset.</p> <p>'5' represents that the overload thermal integral is not accumulated, when the load current is less than 1.5 times the rated motor current, the current thermal integral will be reset.</p> <p><b>Note: Please be careful when F7.01 is set to '1' ~ '5' , the motor might be burnt out.</b></p>
F7.02	Main OV. protect val	(100~130)%U <sub>e</sub>	120%U <sub>e</sub>	In any state ( except the fault state ), when the main circuit voltage is detected to be higher than the F7.02 setting and the duration is longer than the F7.03 setting, the product will report the ' Main circuit OV. '.
F7.03	Main OV. filter time	(0.1~10.0)s	3.0s	
F7.04	Main UV. protect val	(60~90)%U <sub>e</sub>	80%U <sub>e</sub>	In any state ( except the fault state ), when the main circuit voltage is detected to be lower than the F7.04 setting and the duration is longer than the F7.05 setting, the product will report the ' Main circuit UV. '.
F7.05	Main UV. filter time	(0.1~10.0)s	3.0s	

Code	Content	Setting range	Default Value	Parameter details explained
F7.06	LockRotor prot l.val	(600~750)%le	700%le	When the current is detected to be higher than the F7.06 setting and the duration is longer than the F7.07 setting, the product will report the ' Lock rotor/short'.
F7.07	LockRotor time	(0.1~5.0)s	3.0s	
F7.08	I. unbalance degree	(10~50)%	30%	Under the circumstances that the current values of each phase are higher than 5 % le in soft start, Soft start status, Onlin/bypass status , Low fwd status or Low rev status the ' Unbalance of I. ' will be reported when the three-phase current unbalance ( the duration is equal to the F7.09 setting ) is longer than the F7.08 setting. le.: When the duration (I_min / I_max ) *100 < 100 - F7.08 ) is longer than F7.09 setting, the ' Unbalance of I.' is reported. the product will report the ' three-phase unbalance fault ' . <b>Note : I_min represents the smallest phase current, and I_max represents the largest phase current .</b>
F7.09	I. unbalance time	(1.0~20.0)s	3.0s	
F7.10	Start times	0~10	0	When start frequency is higher than the setting value, the product will report the ' too many starts' . When it is set to ' 0' , the start frequency is unlimited. <b>Note:When fault 'Limit I. timeout' or ' over load' of operationoccurs, please wait for 30 minutes and then start it again.</b>
F7.11	SS OH. protect val	(75°C~90) °C	80°C	In any state ( except the fault state ), when the temperature of the soft starter radiator is detected to exceed the overheat protection setting value, the soft starter overheat protection will be reported and the machine will be shut down.
F7.12	SS OH. alarm value	(65°C~74) °C	70°C	In any state ( except the fault state ), when the temperature of the soft starter is detected to be higher than F7.12 setting, the product will report the 'soft starter overheat warning' . In the 'soft starter overheat fault' state, if the soft starter temperature is detected to be 2 °C lower than the F7.12 setting value, the ' soft starter overheating warning ' will be automatically lifted. Default setting of 150A above products is 74°C. Default setting of 150A and below products is 70°C. <b>Note: SS will not stop in the state of " SS OH. alarm " , and if " SS OH. alarm " has been reported in the ready state, it can not be soft started.</b>
F7.13	Underload alarm I.	(0~90) %le	0%le	' 0' represents that this function is invalid. The others represent that the function is valid. In the online operation state, when the motor current is detected to be less than the F7.13 setting current in a continuous period (F7.14 setting), the product will report an ' under load alarm ' . If the parameter (F5.14) is set to ' 0 ' or ' 24 ' , the K3 relay will keep operation and the product will not stop. When the ' underload alarm ' occurs, the motor current is detected to be larger than the F7.13 setting current in a continuous period (F7.15 setting), the ' under load alarm ' will be automatically stopped, and the K3 relay will keep operation.
F7.14	UL.I. keep time	(0.1~60.0) s	5.0s	See F7.13.
F7.15	UL.I.remove keep tim	(0.1~60.0) s	5.0s	
<b>Group F8: Interface Group</b>				
F8.00	Parameter set lock	0: Unlock 1: Lock	0: Unlock	When the local panel communication is effective : it can allow or prohibit the modification of the parameters on the display screen ( except the manufacturer parameters ) . When the remote communication is effective, the lock function is invalid.

Code	Content	Setting range	Default Value	Parameter details explained
F8.01	LCD light close time	(0~600) s	30s	0: LCD backlight is normally on. (1~600)s: After stoping pressing the button on the LCD screen, the backlight will be turned off according to F8.01 settings.
<b>Group F9: Communication para Group</b>				
F9.00	SS Comm address	1~247	1	It represents the communication address of the soft starter in the communication system
F9.01	Comm baud rate	0: 4.8kbps 1: 9.6kbps 2: 19.2kbps	1: 9.6kbps	The baud rate of remote communication
F9.02	Comm data chk format	0: 8-1-N RTU 1: 8-1-E RTU 2: 8-1-O RTU 3: 8-1-N ASCII 4: 8-1-E ASCII 5: 8-1-O ASCII	0: 8-1-N RTU	Communication format 0: 8-1-N RTU: 8 data-bits + 1stop-bit + Non-parity RTU data format 1: 8-1-E RTU: 8 data-bits + 1 stop-bit + Even-parity RTU data format 2: 8-1-O RTU: 8 data-bits + 1 stop-bit + Odd-parity RTU data format 3: 8-1-N ASCII: 8 data-bits + 1 stop-bit + Non-parity ASCII data format 4: 8-1-E ASCII: 8 data-bits + 1 stop-bit + Even-parity ASCII data format 5: 8-1-O ASCII: 8 data-bits + 1 stop-bit + Odd-parity ASCII data format
F9.03	Comm timeout flt tim	(0.1~60.0) s	2.0s	When the time exceeds F9.03 and no communication data are detected, the host computer will report the timeout fault.
<b>Group FA: Status info inquiry Group</b>				
FA.00	Software version	X.XX	/	The current version of main board software and display board software.
FA.01	Software updata(Y)	XXXX(year)	/	Upgrade year of main board software and display board software
FA.02	Software updata (M&D)	XX(month)XX(date)	/	Upgrade date and month of main board software and display board software
FA.03	R Phase current	(0~65535) A	/	Measured value.
FA.04	S Phase current	(0~65535) A	/	<b>Note: Product with rated current of 630A and below for soft starter will keep one decimal point. Product with rated current of 630A above for soft starter will keep integer.</b>
FA.05	T Phase current	(0~65535) A	/	
FA.06	R Phase voltage	(0.0~1000.0) V	/	
FA.07	S Phase voltage	(0.0~1000.0) V	/	Measured value
FA.08	T Phase voltage	(0.0~1000.0) V	/	
FA.09	R&S line voltage	(0.0~1500.0) V	/	
FA.10	R&T line voltage	(0.0~1500.0) V	/	Measured value
FA.11	S&T line voltage	(0.0~1500.0) V	/	
FA.12	R radiator temperat	(0~100.0) °C	/	
FA.13	S radiator temperat	(0~100.0) °C	/	
FA.14	T radiator temperat	(0~100.0) °C	/	

Code	Content	Setting range	Default Value	Parameter details explained
FA.15	Grid frequency	(0~100)Hz	/	Measured value
FA.16	Power factor	0.00~1.00	/	Measured value
FA.17	Active power[kW]	(0.0~6500.0) kW	/	Measured value
FA.18	Reactive power[kvar]	(0.0~6500.0) kvar	/	Measured value
FA.19	Apparent power [kVA]	(0.0~6500.0) kVA	/	Measured value
FA.20	Electromagnetic tor	(0.0~300.0) %	/	Measured value
FA.21	Max I. of running	(0~65535) A	/	Measured value
FA.22	Max I. of start	(0~65535) A	/	Measured value
FA.23	Times of started	0~60000	/	Measured value
FA.24	Pwr consum high[MWH]	(0~9999) MWH	/	Measured value. It is for reference only, and cannot be used as a charge standard.
FA.25	Pwr consum low[kWH]	(0.0~999.9) kWh	/	Measured value. It is for reference only, and cannot be used as a charge standard.
FA.26	Running tim high[kH]	(0~9999) kH	/	Measured value
FA.27	Running time low[H]	(0.0~999.9) H	/	Measured value
FA.28	Pwr on time high[kH]	(0~9999) kH	/	Measured value
FA.29	Pwr on time low[H]	(0.0~999.9) H	/	Measured value
FA.30	Total fault times	0~60000	/	Measured value
FA.31	Grid voltage level	0: AC220V 1: AC380V 2: AC460V 3: AC575V 4: AC690V	1: AC380V	It is decided by factory parameters.
<b>Group FB: Enhance Group</b>				
FB.00	OnLin/ bypass chg dly	(1~20) s	1s	In the soft start state, after detecting that the motor speed reaches the max., the time of FB.00 setting value should be delayed to switch to online operation state or bypass operation state.
FB.01	1# rated power	(1~10000) kW	= F0.04	The rated power of the 1st motor must be accurately input when the starting mode is linear torque or square torque.
FB.02	1# rated speed	(1~3000) RPM	1440RPM	The rated speed of the 1st motor must be accurately input when the starting mode is linear torque or square torque.
FB.03	1# stator loss gain	(20~500) %	100%	It is effective when the starting mode is linear torque or square torque, and it is the gain of stator loss which is related to stator resistance of 1st motor.
FB.04	1# torque lim times	(50.0~300.0) %	150.0%	It is effective when the starting mode is linear torque or square torque, and it is the upper torque limit setting for the start of the 1st motor. The larger this setting is, the easier the motor will start.
FB.05	2# rated power	(0~10000) kW	= F0.04	The rated power of the 2nd motor must be accurately input when the starting mode is linear torque or square torque.

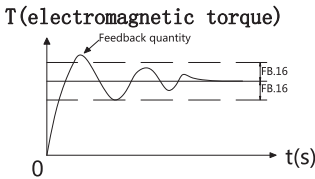
Code	Content	Setting range	Default Value	Parameter details explained
FB.06	2# rated speed	(0~3000) RPM	1440RPM	The rated speed of the 2nd motor must be accurately input when the starting mode is linear torque or square torque.
FB.07	2# stator loss gain	(20~500) %	100%	It is effective when the starting mode is linear torque or square torque, and it is the gain of stator loss which is related to stator resistance of 2nd motor.
FB.08	2# torque lim times	(50.0~300.0) %	150.0%	It is effective when the starting mode is linear torque or square torque, and it is the upper torque limit setting for the start of the 2nd motor. The larger this setting is, the easier the motor will start.
FB.09	3# rated power	(0~10000) kW	=F0.04	The rated power of the 3rd motor must be accurately input when the starting mode is linear torque or square torque.
FB.10	3# rated speed	(0~3000) RPM	1440RPM	The rated speed of the 3rd motor must be accurately input when the starting mode is linear torque or square torque.
FB.11	3# stator loss gain	(20~500) %	100%	It is effective when the starting mode is linear torque or square torque, and it is the gain of stator loss which is related to stator resistance of 3rd motor.
FB.12	3# torque lim times	(50.0~300.0) %	150.0%	It is effective when the starting mode is linear torque or square torque, and it is the upper torque limit setting for the start of the 3rd motor. The larger this setting is, the easier the motor will start.
FB.13	Tor md scal gain(kp)	1~10	4	It is effective when the starting mode is linear torque or square torque. If the proportional gain of the torque PI regulator is adjusted only by the proportional gain KP, the deviation cannot be completely eliminated. In order to eliminate the residual deviation, the integrating time Ti can be used to form a closed-loop control. The smaller Ti is, the faster the response to the deviation will be. but too small size is easy to produce oscillation. In general, it does not need to be modified.
FB.14	Tor md integ tim(Ti)	500~10000	1000 (Number of grid cycles)	It is effective when the starting mode is linear torque or square torque. The integrating time of torque PI regulator does not need to be modified in general.
FB.15	Tor md sample period	1~100	1 (Number of grid cycles)	It is effective when the starting mode is linear torque or square torque. The torque sampling period of torque PI regulator focuses on feedback quantity, which is calculated once in the closed-loop regulator in each sampling period. The larger the sampling period is, the slower the response will be. In general, it does not need to be modified.
FB.16	Tor md deviation lim	(0.0~10.0) %Te	1.0%Te	<p>When it is detected that the deviation between the current electromagnetic torque and the given torque is within the range of FB.16, PI regulator wouldn't be adjusted. See figure 6.11. In general, it does not need to be modified.</p>  <p style="text-align: center;"><b>T(electromagnetic torque)</b></p> <p style="text-align: center;">Feedback quantity</p> <p style="text-align: right;"><math>t(s)</math></p> <p style="text-align: center;"><b>Figure 6.11 PI Regulation Diagram</b></p>
FB.17	Fan run time aft stp	(1~600) s	120s	After the product is shut down (i.e. the motor has no current), the fan will continue to run according to FB.17 settings, and then be turned off.



Code	Content	Setting range	Default Value	Parameter details explained
FB.18	I.md angle back val	(0~200) $\mu$ s	100 $\mu$ s	It is only effective when the starting mode is normal current mode or enhanced current mode. In general, it does not need to be modified.
FB.19	I.md cur rise limit	(10~50%)Ie	20%Ie	
<b>Group FC: Service Group</b>				
FC.00	R phase V.adjust coe	(90~110) %Ue	102% Ue	It is the proportional coefficient of R-phase voltage calibration that cannot be restored to the factory default settings.
FC.01	S phase V.adjust coe	(90~110) %Ue	102% Ue	It is the proportional coefficient of S-phase voltage calibration that cannot be restored to the factory default settings.
FC.02	T phase V.adjust coe	(90~110) %Ue	102% Ue	It is the proportional coefficient of T-phase voltage calibration that cannot be restored to the factory default settings.
FC.03	R pha I.ad scale coe	(90~110) %Ie	100% Ie	FC.03 is the proportional coefficient of R-phase current calibration, FC.04 is the constant of R-phase current calibration. Both cannot be restored to the factory default settings. If the error value, which between the current value displayed on the soft starter operation panel and the actual current value of the motor, becomes larger in proportion to the actual current value, then the setting value of FC.03 should be adjusted. If the error value, which between the current value displayed on the soft starter operation panel and the actual current value of the motor, is fixed and irrelevant to the actual current value, then the setting value of FC.04 should be adjusted.
FC.04	R pha I.ad constant	(0~10) %Ie	0% Ie	
FC.05	S pha I.ad scale coe	(90~110) %Ie	100% Ie	The function is the same as F3.03 and F3.04.
FC.06	S pha I.ad constant	(0~10) %Ie	0% Ie	
FC.07	T pha I.ad scale coe	(90~110) %Ie	100% Ie	The function is the same as F3.03 and F3.04.
FC.08	T pha I.ad constant	(0~10) %Ie	0% Ie	
FC.09	Analog output ad coe	(90~110) %	100%	It is the proportional coefficient of analog output calibration that cannot be restored to the factory default settings.
<b>Group FD: Fault info inquiry Group</b>				
FD.00	Fault info 0	----		The recorded information is as follows when fault/alarm happens: Name of fault/alarm (1 byte) 、 Maximum thermal temperature (1 byte, integer) 、 Working status (2 byte) 、 R-phase current(2 byte, integer) 、 S-phase current(2 byte, integer) 、 T-phase current(2 byte, integer) 、 R-phase voltage (2 byte, integer) 、 S-phase voltage (2 byte, integer) 、 T-phase voltage (2 byte, integer) 、 16 bytes in all 10 pieces of fault information are recorded. <b>Note: Each message contains 16 bytes, i.e. 8 words. Therefore, when reading fault information, the number of data words read at one time must be an integer multiple of 8.</b>
FD.01	Fault info 1			
FD.02	Fault info 2			
FD.03	Fault info 3			
FD.04	Fault info 4			
FD.05	Fault info 5			
FD.06	Fault info 6			
FD.07	Fault info 7			
FD.08	Fault info 8			
FD.09	Fault info 9			

## 7 RS485 communication

The soft starter provides RS485 communication interface and adopts Modbus communication protocol of international standard for master-slave communication. Users can realize centralized control through computer, PLC or special communication equipment, and set the running command of soft starter, modify or read the function code parameters, read the working state and fault information of soft starter, etc. through this communication protocol.

### 7.1 Communication connection

The communication interface adopts RS485, asynchronous communication, and the data frame sending order is high byte first and low byte later (except CRC check code, low byte first and high byte later), and each single byte sending order is the lowest bit first and the highest bit last. The schematic diagram of the connection between a soft starter and a computer is shown in Figure 7.1. See Figure 7.2 for the schematic diagram of the connection between multiple soft starters and computers. The "485+" and "485-" terminals of the external control terminal of the soft starter are respectively connected with the 485+ and 485- terminals of the host computer (upper computer) through twisted pair.

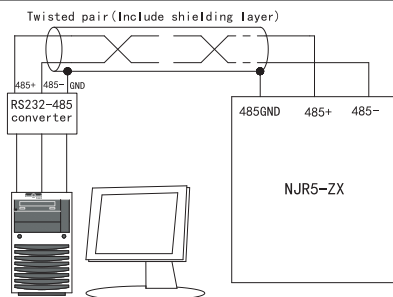

Figure 7.1 Connection between a soft starter and a computer

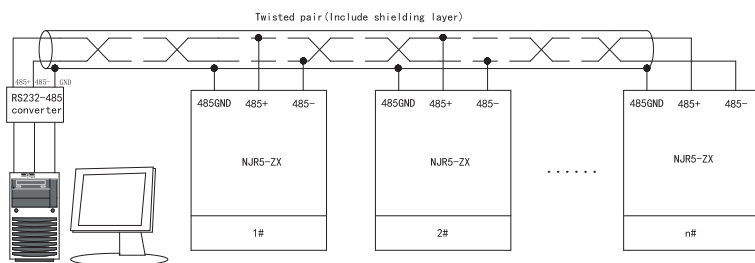

Figure 7.2 Connection between multiple soft starters and computers

**Note:** In general, the terminals of soft starter 485+ and 485- do not need to be connected with terminal resistors. If the distance is far away, the terminal resistors can be indirectly connected to the terminals of soft starter 485+ and 485- at the farthest end (the resistance value of terminal resistors is about 120Ω).

**Note:** In order to reduce the external interference of communication signals, it is recommended to use twisted-pair shielded wires for communication connection lines. If the bus length is long, please connect the "485GND" terminal of the external control terminal of the soft starter with the shielded layer of twisted-pair shielded wires.

## 7.2 content of agreement

The slave address can be set, ranging from 1 to 247, and 0 is the broadcast address. In single master multi-slave system and single master single slave system, the address of each slave in the network is unique. Modbus protocol is supported. The serial communication protocol defines the frame content and usage format of asynchronous transmission in serial communication, and supports RTU and ASCII code formats.

In RTU communication mode, each 8-bit byte in the message contains two 4-bit hexadecimal characters. The advantage of this mode is that its higher character density has higher throughput than ASCII mode at the same baud rate, and the maximum RTU frame of NJR5-ZX soft starter is 256 bytes.

In ASCII communication mode, two ASCII characters are used to send an 8-bit byte in the message. When the device cannot meet RTU mode, ASCII mode is used. The maximum ASCII frame of NJR5-ZX soft starter is 256 characters. See Table 7.1 for ASCII code values corresponding to common characters.

**Table 7.1 ASCII code values corresponding to common characters**

character	'0'	'1'	'2'	'3'	'4'	'5'	'6'	'7'	'8'	'9'
ASCII code value	0x30	0x31	0x32	0x33	0x34	0x35	0x36	0x37	0x38	0x39
character	'A'	'B'	'C'	'D'	'E'	'F'	':'	'CR'	'LF'	
ASCII code value	0x41	0x42	0x43	0x44	0x45	0x46	0x3A	0x0D	0x0A	

## 7.3 protocol format

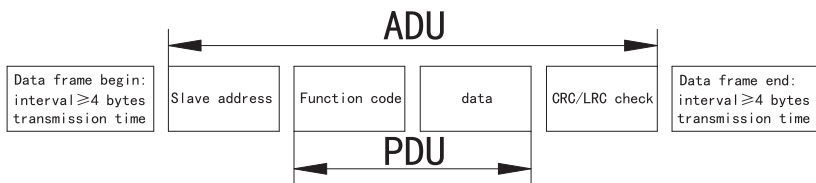

**Figure 7.3 Protocol Format Diagram**

ADU(Application Data Unit) is an application data unit, and PDU(Protocol Data Unit) is a protocol data unit. The 16-bit check code of CRC/LRC is obtained by checking the data of the first three parts of adu. CRC check code is the check code in RTU mode, with low byte in front and high byte in back, while LRC check code is the check code in ASCII mode, with high byte in front and low byte in back.

### 7.3.1 RTU frame standard structure

See table 7.2 for the standard structure of RTU frame. The information of a frame must be transmitted as a continuous data. If the transmission interval time exceeds 1.5 bytes before the end of the whole frame transmission, the receiving device (generally referred to as the lower computer) will clear the incomplete information and mistakenly think that the next byte is the address part of the new frame. Similarly, If the interval between the start of a new frame and the previous frame is less than 3.5 bytes transmission time, the receiving device will consider it as the continuation of the previous frame, and the final CRC check value is incorrect due to the frame disorder.

**Table 7.2 RTU frame standard structure**

Frame START	T1-T2-T3-T4 (transmission time of 4 bytes)
Slave ADDRess addr	Mailing address: 1~247 (single byte, decimal, 0 is broadcast address)
Operation CMD	0x03: Read single or multiple slave parameter register values (single byte, hexadecimal) 0x04: Read single or multiple slave parameter attribute register values (single byte, hexadecimal, integer multiple of 5 registers) 0x06: Write a single slave parameter register value (single byte, hexadecimal) 0x10: Write multiple slave parameter register values (single byte, hexadecimal)
DATA(N-1)...DATA(0)	2N bytes of data, which is the core content of communication (2N bytes)
CRC check	CRC check value, with special check program (double bytes)
END of frame	T1-T2-T3-T4 (transmission time of 4 bytes)

### 7.3.2 ASCII frame standard structure

See Table 7.3 for the standard structure of ASCII frames. In ASCII mode, the frame header is ":"(0x3a) and the frame trailer is "CRLF" (0x0D" 0x0A). In ASCII mode, except the frame header and frame trailer, all other data bytes are sent in ASCII code format (see Table 6.1). The upper 4 bytes are sent first, then the lower 4 bytes are sent. The check code LRC is used to check, and the check content covers three parts, from the slave address to the data information. The check code is equal to the complement of the sum of all characters participating in the check data.

**Table 7.3 Standard Structure of ASCII Frame**

Frame START	": "
Slave ADDRess addr	Communication address: 1~247. The slave address (8 bits of data) consists of two ASCII codes.
Operation CMD	0x03: Read single or multiple slave parameter register values (single byte, hexadecimal) 0x04: Read single or multiple slave parameter attribute register values (single byte, hexadecimal, The number of registers is an integer multiple of 5) 0x06: Write a single slave parameter register value (single byte, hexadecimal) 0x10: Write multiple slave parameter register values (single byte, hexadecimal). Each function code (8 bits of data) consists of two ASCII codes.
DATA(N-1)...DATA(0)	2N bytes of data, which is the core content of communication (2N bytes), and each data bit (8 bits of data) consists of two ASCII codes.
CRC check	LRC check value consists of two data bits, and each data bit (8 data bits) consists of two ASCII codes.
END of frame	It consists of two ASCII codes, 0x0D and 0x0A.

### 7.4 Test code generation mode

The frame check method mainly includes two parts of check, that is, byte bit check and frame data check, while frame data check includes CRC check (RTU mode) and LRC check (ASCII mode).

#### 7.4.1 byte bit check

Users can choose different bit check modes according to their needs, or choose no check, which will affect the check bit setting of each byte.

Meaning of parity check: an even parity bit is added before data transmission to indicate whether the number of "1s" in the transmitted data is odd or even. If it is even, the check position is "0", otherwise, it is set to "1" to keep the parity of the data unchanged.

Meaning of odd parity: an odd parity bit is added before data transmission, which is used to indicate whether the number of "1" in the transmitted data is odd or even. If it is odd, the check position is "0", otherwise, it is set to "1" to keep the parity of the data unchanged.

For example, "11001110" needs to be transmitted, and there are five "1s" in the data. If even parity is used, the even parity bit is "1", if with odd parity, the odd parity bit is "0". When transmitting data, the parity bit is calculated and placed in the parity bit position of the frame, and the receiving device should also carry out parity check. If it is found that the parity of the received data is inconsistent with the preset, it is considered that the communication has made an error.

#### 7.4.2 CRC check method ---CRC (Cyclical Redundancy Check)

Using RTU frame format, the frame includes the frame error detection field calculated based on CRC method. CRC field detects the content of the whole frame. The CRC field is two bytes and contains 16 bits of binary value. It is calculated by the transmission device and added to the frame. The receiving device recalculates the CRC of the received frame and compares it with the value in the received CRC field. If the two CRC values are not equal, it indicates that there is an error in transmission.

CRC is to store 0xFFFF first, and then call a procedure to process more than 6 consecutive bytes in the frame with the value in the current register. Only 8Bit data in each character is valid for CRC, and the start and stop bits and parity bits are invalid. In the process of CRC generation, each 8-bit character is independently exclusive OR (XOR) with the register content, and the result moves to the least significant bit direction. Most significant bit is filled with 0. The LSB is extracted for detection. If the LSB is 1, the register is exclusive or different from the preset value; if the LSB is 0, it will not be performed. The whole process should be repeated eight times. After the last bit (the eighth bit) is completed, the next 8-bit byte is separately or different from the current value of the register. The value in the final register is the CRC value after all the bytes in the frame are executed. This calculation method of CRC adopts the international standard CRC check rule. When editing the CRC algorithm, users can refer to the relevant standard CRC algorithm and write a CRC calculation program that really meets the requirements. Now provide a simple function of CRC calculation for users' reference (programmed in C language):

```
unsigned int crc_cal_value(unsigned char
*data_value, unsigned char data_length)
{
    int i;
    unsigned int crc_value=0xffff;
    while(data_length--)
    {
        crc_value ^= *data_value++;
        for(i=0; i<8; i++)
        {
            if(crc_value & 0x0001) crc_value = (crc_value >> 1) ^ 0xa001;
            else crc_value = crc_value >> 1;
        }
    }
    return(crc_value);
}
```

In ladder logic, CKSM can calculate CRC value according to the frame content, or look-up table method can be used to calculate CRC value. This method is simple in program and fast in operation, but the program occupies a large amount of ROM space, so please use it with caution when there is a requirement for program space.

#### 7.4.3 ASCII mode check (LRC Check)

Check code (LRC Check) is added by slave address, function code and data in ADU, and then the lower 8 digits are taken, and then the complement is taken. Table 7.5 Calculation process of LRC check code: 0x01+0x03+0x01+0x00+0x00+0x01 = 0x06 → the complement of 0x06 is 0xfa → the ASCII codes corresponding to 0xfa are 0x46 and 0x41 respectively.

#### 7.5 Description of function code

This paper mainly describes the RTU data format and application of common functions in Modbus protocol. The ASCII format only needs to modify the header and inspection mode in the data format to LRC mode, and then split each data in the data packet in RTU into two data to send. NJR5-ZX series products support four function codes, namely 0x03, 0x04, 0x06 and 0x10.

### 7.5.1 0x03 function code

Read the values of one or more slave parameter registers. NJR5-ZX series soft starter (assuming slave address =1, that is, F9.00=1) can read the values of relevant parameters through this function code, for example, read the current values of the function parameter F1.00 (F1.00 is set to 3 at this time). See Table 7.4 and Table 7.5 in RTU mode and ASCII mode respectively.

**Table 7.4 0x03 Function Code (RTU Mode)**

Host command information		Slave response information	
begin	3.5 bytes transmission interval time	Slave address	3.5 bytes transmission interval time
Slave address	0x01	Slave address	0x01
function code	0x03	function code	0x03
Register start address high bit	0x01	Number of bytes	0x02
Register start address low bit	0x00	Address 0x0100 high bit	0x00
Number of registers high	0x00	Address 0x0100 Low Bit	0x03
Low number of registers	0x01	Low bit of CRC check code	0xF8
Low bit of CRC check code	0x85	CRC check code high bit	0x45
CRC check code high bit	0xF6	end	3.5 bytes transmission interval time
end	3.5 bytes transmission interval time		

**Table 7.5 0x03 Function Code (ASCII Mode)**

Host command information		Slave response information	
begin	0x3A	begin	0x3A
Slave address	0x30	Slave address	0x30
	0x31		0x31
function code	0x30	function code	0x30
	0x33		0x33
Register start address high bit	0x30	Number of bytes	0x30
	0x31		0x32
Register start address low bit	0x30	Address 0x0100 high bit	0x30
	0x30		0x30
Number of registers high	0x30	Address 0x0100 Low Bit	0x30
	0x30		0x33
Low number of registers	0x30	LRC check code high bit	0x46
	0x31	LRC check code low bit	0x37
LRC check code high bit	0x46	end	0x0D
LRC check code low bit	0x41		0x0A
end	0x0D		
	0x0A		

**Note:** The sending order of CRC check code is high bit first and low bit later, while the sending order of LRC check code is low bit first and high bit later.

### 7.5.2 0x04 function code

Function code 0x04 means to read the attribute of this parameter, which means to read the attribute of this parameter. The number of readings must be a multiple of 5. The attribute contains five 16-bit data, and the definitions are shown in Table 7.6 respectively. For example, read the current attribute of parameter F2.01 (at this time, the value of F2.01 is 15A). See Table 7.7 and Table 7.8 in RTU mode and ASCII mode respectively.

**Table 7.6 Meaning of register parameters**

Attribute of slave parameter register value	meaning												
The first attribute word	Maximum value of register parameter												
The second attribute word	Minimum value of register parameter												
The third attribute word	Current value of register parameter												
The fourth attribute word	<table border="1"> <thead> <tr> <th>Bit number</th> <th>meaning</th> </tr> </thead> <tbody> <tr> <td>Bit 14-15</td> <td>reserve</td> </tr> <tr> <td>Bit 11-13</td> <td>                     Modify attributes                      0x00: It means readable and writable, and the general function parameters are                      0x02: It means read-only, such as current temperature display.                      0x04: Only the manufacturer's permission can be written, such as rated model current of soft starter.                 </td> </tr> <tr> <td>Bit 8-10</td> <td>                     Data type                      0x01:8-bit unsigned integer data                      0x02:16-bit unsigned integer data                 </td> </tr> <tr> <td>Bit 5-7</td> <td>                     Magnification times                      0x00: Multiply by 1                      0x01: Multiply by 0.1                      0x02: Multiply by 0.01                      0x03: Multiply by 0.001                      0x04: Multiply by 0.0001                      0x05: Multiply by 0.00001                 </td> </tr> <tr> <td>Bit 0-4</td> <td>                     Unit                      0x00: No unit                      0x01: Voltage (V)                      0x02: Current (A)                      0x03: Power (kW)                      0x04: Reactive power (kvar)                      0x05: Apparent power (kVA)                      0x06: Power consumption (MWH)                      0x07: Electricity consumption (kWH)                      0x08: Frequency (Hz)                      0x09: Time (kH)                      0x0A: Time (H)                      0x0B: Time (s)                      0x0C: Time (ms)                      0x0D: Time (μs)                      0x0E: Temperature (°C)                      0x0F: Percentage of rated model voltage of main circuit of soft starter (%Un)                      0x10: Percentage of rated voltage of motor (%Ue)                      0x11: Percentage of rated model voltage of soft starter control loop (%Us)                      0x12: Percentage of rated model current of soft starter (%In)                      0x13: Percentage of rated current of motor (%Ie)                      0x14: Motor rated torque percentage (%Te)                      0x15: Percentage (%)                      0x16: Rated speed of motor (RPM)                 </td> </tr> </tbody> </table>	Bit number	meaning	Bit 14-15	reserve	Bit 11-13	Modify attributes 0x00: It means readable and writable, and the general function parameters are 0x02: It means read-only, such as current temperature display. 0x04: Only the manufacturer's permission can be written, such as rated model current of soft starter.	Bit 8-10	Data type 0x01:8-bit unsigned integer data 0x02:16-bit unsigned integer data	Bit 5-7	Magnification times 0x00: Multiply by 1 0x01: Multiply by 0.1 0x02: Multiply by 0.01 0x03: Multiply by 0.001 0x04: Multiply by 0.0001 0x05: Multiply by 0.00001	Bit 0-4	Unit 0x00: No unit 0x01: Voltage (V) 0x02: Current (A) 0x03: Power (kW) 0x04: Reactive power (kvar) 0x05: Apparent power (kVA) 0x06: Power consumption (MWH) 0x07: Electricity consumption (kWH) 0x08: Frequency (Hz) 0x09: Time (kH) 0x0A: Time (H) 0x0B: Time (s) 0x0C: Time (ms) 0x0D: Time (μs) 0x0E: Temperature (°C) 0x0F: Percentage of rated model voltage of main circuit of soft starter (%Un) 0x10: Percentage of rated voltage of motor (%Ue) 0x11: Percentage of rated model voltage of soft starter control loop (%Us) 0x12: Percentage of rated model current of soft starter (%In) 0x13: Percentage of rated current of motor (%Ie) 0x14: Motor rated torque percentage (%Te) 0x15: Percentage (%) 0x16: Rated speed of motor (RPM)
Bit number	meaning												
Bit 14-15	reserve												
Bit 11-13	Modify attributes 0x00: It means readable and writable, and the general function parameters are 0x02: It means read-only, such as current temperature display. 0x04: Only the manufacturer's permission can be written, such as rated model current of soft starter.												
Bit 8-10	Data type 0x01:8-bit unsigned integer data 0x02:16-bit unsigned integer data												
Bit 5-7	Magnification times 0x00: Multiply by 1 0x01: Multiply by 0.1 0x02: Multiply by 0.01 0x03: Multiply by 0.001 0x04: Multiply by 0.0001 0x05: Multiply by 0.00001												
Bit 0-4	Unit 0x00: No unit 0x01: Voltage (V) 0x02: Current (A) 0x03: Power (kW) 0x04: Reactive power (kvar) 0x05: Apparent power (kVA) 0x06: Power consumption (MWH) 0x07: Electricity consumption (kWH) 0x08: Frequency (Hz) 0x09: Time (kH) 0x0A: Time (H) 0x0B: Time (s) 0x0C: Time (ms) 0x0D: Time (μs) 0x0E: Temperature (°C) 0x0F: Percentage of rated model voltage of main circuit of soft starter (%Un) 0x10: Percentage of rated voltage of motor (%Ue) 0x11: Percentage of rated model voltage of soft starter control loop (%Us) 0x12: Percentage of rated model current of soft starter (%In) 0x13: Percentage of rated current of motor (%Ie) 0x14: Motor rated torque percentage (%Te) 0x15: Percentage (%) 0x16: Rated speed of motor (RPM)												
The fifth attribute word	reserve												

**Table 7.7 0x04 Function Code (RTU Mode)**

Host command information		Slave response information	
begin	3.5 bytes transmission interval time	begin	3.5 bytes transmission interval time
Slave address	0x01	Slave address	0x01
function code	0x04	function code	0x04
Register start address high bit	0x02	Number of bytes	0x0A
Register start address low bit	0x01	Parameter F2.01 first attribute word high order	0x00
Number of registers high	0x00	Parameter F2.01 first attribute word low bit	0x0F
Low number of registers	0x05	Parameter F2.01 second attribute word high order	0x00
Low bit of CRC check code	0x60	Parameter F2.01 second attribute word low bit	0x03
CRC check code high bit	0x71	Parameter F2.01 third attribute word high order	0x00
end	3.5 bytes transmission interval time	Parameter F2.01 third attribute word low bit	0x0F
		Parameter F2.01 The fourth attribute word high bit	0x01
		Parameter F2.01 The fourth attribute word low bit	0x02
		Parameter F2.01 The fifth attribute word high bit	0x00
		Parameter F2.01 fifth attribute word low bit	0x02
		Low bit of CRC check code	0xD6
		CRC check code high bit	0x71
		end	3.5 bytes transmission interval time

**Table 7.8 0x04 function code (ASCII mode)**

Host command information		Slave response information	
begin	0x3A	begin	0x3A
Slave address	0x30	Slave address	0x30
	0x31		0x31
function code	0x30	function code	0x30
	0x34		0x34
Register start address high bit	0x30	Number of bytes	0x30
	0x32		0x41
Register start address low bit	0x30	Parameter F2.01 first attribute word high order	0x30
	0x31	Parameter F2.01 first attribute word low bit	0x30
Number of registers high	0x30	Parameter F2.01 second attribute word high order	0x30
	0x30	Parameter F2.01 second attribute word low bit	0x30
Low number of registers	0x30	Parameter F2.01 third attribute word high order	0x30
	0x35	Parameter F2.01 third attribute word low bit	0x30
LRC check code high bit	0x46	Parameter F2.01 The fourth attribute word high bit	0x30
			0x31
LRC check code low bit	0x33	Parameter F2.01 The fourth attribute word low bit	0x30
			0x32



**Table 7.8 (Continued)**

Host command information		Slave response information	
end	0x0D	Parameter F2.01 The fifth attribute word high bit	0x30
			0x30
	0x0A	Parameter F2.01 fifth attribute word low bit	0x30
			0x32
		LRC check code high bit	0x43
		LRC check code low bit	0x42
		end	0x0D
			0x0A

### 7.5.3 0x06 function code

Write a word of data to the slave register, that is, set the value of a single parameter. For example, write data "2" to parameter F1.00, see Table 7.9 and Table 7.10 in RTU mode and ASCII mode respectively.

**Table 7.9 0x06 Function Code (RTU Mode)**

Host command information		Slave response information	
begin	3.5 bytes transmission interval time	Slave address	3.5 bytes transmission interval time
Slave address	0x01	Slave address	0x01
function code	0x06	function code	0x06
Register start address high bit	0x01	Register start address high bit	0x01
Register start address low bit	0x00	Register start address low bit	0x00
High bit of register content	0x00	High bit of register content	0x00
Low bit of register content	0x02	Low bit of register content	0x02
Low bit of CRC check code	0x09	Low bit of CRC check code	0x09
CRC check code high bit	0xF7	CRC check code high bit	0xF7
end	3.5 bytes transmission interval time	end	3.5 bytes transmission interval time

**Table 7.10 0x06 Function Code (ASCII Mode)**

Host command information		Slave response information	
begin	0x3A	begin	0x3A
Slave address	0x30	Slave address	0x30
	0x31		0x31
function code	0x30	function code	0x30
	0x36		0x36
Register start address high bit	0x30	Register start address high bit	0x30
	0x31		0x31
Register start address low bit	0x30	Register start address low bit	0x30
	0x30		0x30
Register content high bit	0x30	Register content high bit	0x30
	0x30		0x30
Low register content	0x30	Low register content	0x30
	0x32		0x32
LRC check code high bit	0x46	LRC check code high bit	0x46
LRC check code low bit	0x36	LRC check code low bit	0x36
end	0x0D	end	0x0D
	0x0A		0x0A

### 7.5.4 0x10 function code

Write multiple words of data to the slave register continuously, that is, set the values of multiple continuous parameters. For example, write data "0x03" and "0x02", RTU parameters F1.00 and F1.01. See Table 7.11 and Table 7.12 in RTU mode and ASCII mode respectively.

**Table 7.11 0x10 function code (RTU mode)**

Host command information		Slave response information	
begin	3.5 bytes transmission interval time	Slave address	3.5 bytes transmission interval time
Slave address	0x01	Slave address	0x01
function code	0x10	function code	0x10
Register start address high bit	0x01	Register start address high bit	0x01
Register start address low bit	0x00	Register start address low bit	0x00
Number of register words high bit	0x00	Number of register words high bit	0x00
Low number of register words	0x02	Low number of register words	0x02
Number of register bytes	0x04	Low bit of CRC check code	0x40
Register word content high bit	0x00	CRC check code high bit	0x34
Low register word content	0x03	end	3.5 bytes transmission interval time
Register word content high bit	0x00		
Low register word content	0x02		
Low bit of CRC check code	0x8F		
CRC check code high bit	0xFE		
end	3.5 bytes transmission interval time		

**Table 7.12 0x10 function code (ASCII mode)**

Host command information		Slave response information	
begin	0x3A	begin	0x3A
Slave address	0x30	Slave address	0x30
	0x31		0x31
function code	0x31	function code	0x31
	0x30		0x30
Register start address high bit	0x30	Register start address high bit	0x30
	0x31		0x31
Register start address low bit	0x30	Register start address low bit	0x30
	0x30		0x30
Number of register words high bit	0x30	Number of register words high bit	0x30
	0x30		0x30
Low number of register words	0x30	Low number of register words	0x30
	0x32		0x32
Number of register bytes	0x30	LRC check code high bit	0x45
	0x34	LRC check code low bit	0x43
Register word content high bit	0x30	end	0x0D
	0x30		0x0A
Low register word content	0x30		
	0x33		
Register word content high bit	0x30		
	0x30		
Low register word content	0x30		
	0x32		
LRC check code high bit	0x45		

**Table 7.12 (Continued)**

Host command information		Slave response information
LRC check code low bit	0x33	
end	0x0D	
	0x0A	

### 7.6 Description of functional exception code

If the operation request fails, PDU replies with error code and exception code. The error code is equal to the function code +0x80, and the exception code indicates the specific error reason. See Table 7.13 for the exception code list.

**Table 7.13 Definition of Exception Code**

Exception code (hexadecimal)	Shown meaning
0x01	Illegal function code: the soft starter receives a function code that it does not support.
0x02	<p>Illegal register address: that data address received by the soft start is not allowed.            Example: read the data of register address 0xFF00 address (actually there is no register address 0xFF00)            Data sent by the upper computer (hexadecimal): <b>01 03 FF 00 00 01 87 1E</b>            Lower computer response data (hexadecimal): <b>01 83 02 C0 F1</b></p> <p><b>83: Indicates the function code + 0x80</b> ←</p> <p><b>02: indicates illegal register address</b> ←</p>
0x03	Illegal register data value: the number of PDU data is inaccurate.
0x10	Error check code: the data check code received by the soft starter is wrong.
0x11	Function parameters can't be written: function parameters can only be written in preparation state or failure state, and can't be written in other states.
0x12	Function parameter value out of range: the set function parameter value is out of the allowed range.
0x15	Enterprise password permission: enterprise password is required to read and write.

### 7.7 Communication address

#### 7.7.1 Communication address of function parameter class

R/W means that the function parameter or control command parameter can be read or written, R means that the function parameter or control command parameter can only be read, and W means that the function parameter or control command parameter can only be written. See Table 7.14 for details.

**Table 7.14 Communication address of functional parameters**

Parameter code	Parameter content	Read-write attribute	communication address
F1.00	Start/Stop channel	R/W	0x0100
F1.01	Start delay	R/W	0x0101
F1.02	Sequence start num	R/W	0x0102
F1.03	Strength of low fwd.	R/W	0x0103
F1.04	Speed of low fwd.	R/W	0x0104
F1.05	Strength of low rev.	R/W	0x0105
F1.06	Speed of low rev	R/W	0x0106
F2.00	1# load type sel	R/W	0x0200
F2.01	1# rated current	R/W	0x0201
F2.02	1# start mode	R/W	0x0202
F2.03	1# stop mode	R/W	0x0203
F2.04	1# limit l. times	R/W	0x0204
F2.05	1# jump time	R/W	0x0205

Table 7.14 (Continued)

Parameter code	Parameter content	Read-write attribute	communication address
F2.06	1# jump voltage	R/W	0x0206
F2.07	1# initial voltage	R/W	0x0207
F2.08	1# start time factor	R/W	0x0208
F2.09	1# 2nd limit I. time	R/W	0x0209
F2.10	1# 2nd limit I.times	R/W	0x020A
F2.11	1# sft stp T. factor	R/W	0x020B
F2.12	1# soft stop end V.	R/W	0x020C
F2.13	1# brake stop time	R/W	0x020D
F2.14	1# brake stp strenth	R/W	0x020E
F3.00	2# load type sel	R/W	0x0300
F3.01	2# rated current	R/W	0x0301
F3.02	2# start mode	R/W	0x0302
F3.03	2# stop mode	R/W	0x0303
F3.04	2# limit I. times	R/W	0x0304
F3.05	2# jump time	R/W	0x0305
F3.06	2# jump voltage	R/W	0x0306
F3.07	2# initial voltage	R/W	0x0307
F3.08	2# start time factor	R/W	0x0308
F3.09	2# 2nd limit I. time	R/W	0x0309
F3.10	2# 2nd limit I.times	R/W	0x030A
F3.11	2# sft stp T. factor	R/W	0x030B
F3.12	2# soft stop end V.	R/W	0x030C
F3.13	2# brake stop time	R/W	0x030D
F3.14	2# brake stp strenth	R/W	0x030E
F4.00	3# load type sel	R/W	0x0400
F4.01	3# rated current	R/W	0x0401
F4.02	3# start mode	R/W	0x0402
F4.03	3# stop mode	R/W	0x0403
F4.04	3# limit I. times	R/W	0x0404
F4.05	3# jump time	R/W	0x0405
F4.06	3# jump voltage	R/W	0x0406
F4.07	3# initial voltage	R/W	0x0407
F4.08	3# start time factor	R/W	0x0408
F4.09	3# 2nd limit I. time	R/W	0x0409
F4.10	3# 2nd limit I.times	R/W	0x040A
F4.11	3# sft stp T. factor	R/W	0x040B
F4.12	3# soft stop end V.	R/W	0x040C
F4.13	3# brake stop time	R/W	0x040D
F4.14	3# brake stp strenth	R/W	0x040E
F5.00	Relay valid status	R/W	0x0500
F5.01	IN1 function select	R/W	0x0501
F5.02	IN2 function select	R/W	0x0502
F5.03	IN1 close delay	R/W	0x0503
F5.04	IN1 open delay	R/W	0x0504
F5.05	IN2 close delay	R/W	0x0505
F5.06	IN2 open delay	R/W	0x0506

**Table 7.14 (Continued)**

Parameter code	Parameter content	Read-write attribute	communication address
F5.07	RUN close delay	R/W	0x0507
F5.08	RUN open delay	R/W	0x0508
F5.09	STOP close delay	R/W	0x0509
F5.10	STOP open delay	R/W	0x050A
F5.11	EMS close delay	R/W	0x050B
F5.12	EMS opendelay	R/W	0x050C
F5.13	K2 Relay output sel	R/W	0x050D
F5.14	K3 Relay output sel	R/W	0x050E
F6.00	Analog output Type	R/W	0x0600
F6.01	Analog output Func	R/W	0x0601
F7.00	OLprotect grade	R/W	0x0700
F7.01	OLhot accumulat sel	R/W	0x0701
F7.02	Main OV. protect val	R/W	0x0702
F7.03	Main OV. filter time	R/W	0x0703
F7.04	Main UV. protect val	R/W	0x0704
F7.05	Main UV. filter time	R/W	0x0705
F7.06	LockRotor prot l.val	R/W	0x0706
F7.07	LockRotor time	R/W	0x0707
F7.08	I. unbalance degree	R/W	0x0708
F7.09	I. unbalance time	R/W	0x0709
F7.10	Start times	R/W	0x070A
F7.11	SS OH. protect val	R/W	0x070B
F7.12	SS OH. alarm value	R/W	0x070C
F7.13	Underload alarm l.	R/W	0x070D
F7.14	ULI. keep time	R/W	0x070E
F7.15	ULI.remove keep tim	R/W	0x070F
F8.00	Parameter set lock	R/W	0x0800
F8.01	LCD light close time	R/W	0x0801
F9.00	SS Comm address	R/W	0x0900
F9.01	Comm baud rate	R/W	0x0901
F9.02	Comm data chk format	R/W	0x0902
F9.03	Comm timeout flt tim	R/W	0x0903
FA.00	Software version	R	0x0A00
FA.01	Software updata(Y)	R	0x0A01
FA.02	Software updata(M&D)	R	0x0A02
FA.03	R Phase current	R	0x0A03
FA.04	S Phase current	R	0x0A04
FA.05	T Phase current	R	0x0A05
FA.06	R Phase voltage	R	0x0A06
FA.07	S Phase voltage	R	0x0A07
FA.08	T Phase voltage	R	0x0A08
FA.09	R&S line voltage	R	0x0A09
FA.10	R&T line voltage	R	0x0A0A
FA.11	S&T line voltage	R	0x0A0B
FA.12	R radiator temperat	R	0x0A0C
FA.13	S radiator temperat	R	0x0A0D

**Table 7.14 (Continued)**

Parameter code	Parameter content	Read-write attribute	communication address
FA.14	T radiator temperat	R	0x0A0E
FA.15	Grid frequency	R	0x0A0F
FA.16	Power factor	R	0x0A10
FA.17	Active power[kW]	R	0x0A11
FA.18	Reactive power[kvar]	R	0x0A12
FA.19	Apparent power [kVA]	R	0x0A13
FA.20	Electromagnetic tor	R	0x0A14
FA.21	Max l. of running	R	0x0A15
FA.22	Max l. of start	R	0x0A16
FA.23	Times of started	R	0x0A17
FA.24	Pwr consum high[MWH]	R	0x0A18
FA.25	Pwr consum low[kWH]	R	0x0A19
FA.26	Running tim high[kH]	R	0x0A1A
FA.27	Running time low[H]	R	0x0A1B
FA.28	Pwr on time high[kH]	R	0x0A1C
FA.29	Pwr on time low[H]	R	0x0A1D
FA.30	Total fault times	R	0x0A1E
FA.31	Grid voltage level	R	0x0A1F
FB.00	OnLin/bypass chg dly	R/W	0x0B00
FB.01	1# rated power	R/W	0x0B01
FB.02	1# rated speed	R/W	0x0B02
FB.03	1# stator loss gain	R/W	0x0B03
FB.04	1# torque lim times	R/W	0x0B04
FB.05	2# rated power	R/W	0x0B05
FB.06	2# rated speed	R/W	0x0B06
FB.07	2# stator loss gain	R/W	0x0B07
FB.08	2# torque lim times	R/W	0x0B08
FB.09	3# rated power	R/W	0x0B09
FB.10	3# rated speed	R/W	0x0B0A
FB.11	3# stator loss gain	R/W	0x0B0B
FB.12	3# torque lim times	R/W	0x0B0C
FB.13	Tor md scal gain(kp)	R/W	0x0B0D
FB.14	Tor md integ tim(Ti)	R/W	0x0B0E
FB.15	Tor md sample period	R/W	0x0B0F
FB.16	Tor md deviation lim	R/W	0x0B10
FB.17	Fan run time aft stp	R/W	0x0B11
FB.18	Lmd angle back val	R/W	0x0B12
FB.19	Lmd cur rise limit	R/W	0x0B13
FC.00	R phase Vadjust coe	R/W	0x0C00
FC.01	S phase Vadjust coe	R/W	0x0C01
FC.02	T phase Vadjust coe	R/W	0x0C02
FC.03	R pha Lad scale coe	R/W	0x0C03
FC.04	R pha Lad constant	R/W	0x0C04
FC.05	S pha Lad scale coe	R/W	0x0C05
FC.06	S pha Lad constant	R/W	0x0C06
FC.07	T pha Lad scale coe	R/W	0x0C07

**Table 7.14 (Continued)**

Parameter code	Parameter content	Read-write attribute	communication address
FC.08	T pha Lad constant	R/W	0x0C08
FC.09	Analog output ad coe	R/W	0x0C09
FD.00	Fault info 0	R	0x0D00
FD.01	Fault info 1	R	0x0D01
FD.02	Fault info 2	R	0x0D02
FD.03	Fault info 3	R	0x0D03
FD.04	Fault info 4	R	0x0D04
FD.05	Fault info 5	R	0x0D05
FD.06	Fault info 6	R	0x0D06
FD.07	Fault info 7	R	0x0D07
FD.08	Fault info 8	R	0x0D08
FD.09	Fault info 9	R	0x0D09

## 7.7.2 Communication address of control command class

See Table 7.15 for the communication address of the control class.

**Table 7.15 Communication address of control command**

control command	meaning	Read-write attribute	communication address
Stop command	0x00AA: Start; 0x0055: Stop Note: When the stop command is received, it means resetting the current fault.	W	0x3201
Restore factory value	0x00AA: recovery; 0x0055: No recovery	W	0x3202
Fault clearing	0x00AA: fault clearing; 0x0055: Failure is not cleared.	W	0x3203
Manufacturer permission enable	reserve	W	0x3204
Low speed forward rotation command	0x00AA: low-speed forward rotation; 0x0055: Stop	W	0x3205
Low speed reversal command	0x00AA: low-speed reversal; 0x0055: Stop	W	0x3206
Read the current working state	0x0001: ready status 0x0002: soft start state 0x0004: Bypass operation state or online operation state 0x0008: Soft stop state, including voltage ramp soft stop and torque ramp soft stop. 0x0010: fault status 0x0020: Brake state 0x0040: Low speed forward rotation state 0x0080: Low-speed reverse state	R	0x4201
Read current fault or alarm	0x0000: No fault 000x01: Operation overload fault 0x0002: Locked rotor/short circuit fault 0x0003: Starting current limit timeout fault 0x0004: Three-phase unbalance fault 0x0005: Output phase failure 0x0006: Input phase failure 0x0007: Frequency error fault 0x0008: thyristor short circuit fault 0x0009: Soft starter overheating fault 0x000a: Motor overheat fault 0x000b: Bypass switch failure 0x000c: main circuit overvoltage fault 0x000d: Main circuit undervoltage fault 0x000e: Control voltage overvoltage fault 0x000f: Control voltage undervoltage fault	R	0x4202

**Table 7.15 (Continued)**

control command	meaning	Read-write attribute	communication address
	0x0010: motherboard running timeout failure 0x0011: Open circuit fault of instantaneous stop breaker 0x0012: Too many starts. 0x0013: Long starting time fault 0x0014: Parameter error fault 0x0015: External fault 0x0016: Communication timeout failure 0x0017: Overheating alarm 0x0018: Underload alarm		
Starting countdown value:	1s~999s	R	0x4203
Fault release countdown:	0s~1800s It is only valid when the fault of running overload or starting current limit timeout occurs, and other faults are invalid.	R	0x4204

### 7.8 Example of Modbus communication

Before communication, first set the relevant communication function parameters, and then make the communication address, baud rate and data format of the upper computer and the lower computer consistent.

**Example 1: The model of the soft starter is NJR5-150/ZX3, and the slave address is 0x01. To read the current three-phase current of the soft starter.**

Data sent by the host: **01 03 0A 03 00 03 F6 13**

Data received by the host: **01 03 06 02 E0 02 E2 02 DF 40 37**

The data received by the host computer (lower computer) is the data responded by the slave computer (lower computer). In this communication data, **02 E0** represents R phase current, **02 E2** represents S phase current and **02 DF** represents T phase current.

0x02E0=736, and the rated model current of NJR5-150/ZX3 is 150A, less than or equal to 630A, and the displayed value is with a decimal point, so the actual current of R phase =73.6A,S phase = 73.8A and T phase = 73.5A.

**Example 2: The model of the soft starter is NJR5-1000/ZX3, and the slave address is 0x01. To read the current three-phase current of the soft starter.**

Data sent by the host: **01 03 0A 03 00 03 F6 13**

Data received by the host: **01 03 06 02 E0 02 E2 02 DF 40 37**

The data received by the host computer (lower computer) is the data responded by the slave computer (lower computer). In this communication data, **02 E0** represents R phase current, **02 E2** represents S phase current and **02 DF** represents T phase current.

0x02E0=736, and the rated model current of NJR5-1000/ZX3 is 1000A, greater than 630A, and the displayed value is an integer, so the actual current of R phase =736A,S phase = 738 A and T phase = 735 A.

**Example 3: The slave address of the soft starter is 0x01. To realize soft start through communication, there are two steps.**

**Step 1: Set the start/stop channel of F1.00 to "2" (in fact, it can be set to 4~6, this example is set to "2").**

Data sent by the host: **01 06 01 00 00 02 09 F7**

Data received by the host: **01 06 01 00 00 02 09 F7**

In this way, the function parameter F1.00 is set to "2" (**00 02** represents the value "2").

**Step 2: The host sends a soft start command to the soft starter.**

Data sent by the host: 01 06 32 01 00 AA 56 CD

Data received by the host: 01 06 32 01 00 AA 56 CD

Send the start command 00 AA to the communication address 32 01 of the start-stop command, so that the soft start command sends the start command to the soft starter by communication, thus realizing soft start.



## 8 Fault analysis and troubleshooting

### 8.1 Maintenance

Only when the power supply is turned off before the product maintenance can the product be maintained, and only professionals can disassemble and maintain it.

- A) Check whether the terminal screws are loose;
- B) Check whether the wires are damaged or aged;
- C) Check whether there is any heat trace on the copper bar or conductor part.

### 8.2 Fault protection instructions

NJR5-ZX series soft starter has perfect protection function, which can protect the use safety of soft starter and motor.

The soft starter will stop immediately in case of protection. In use, the protection level and protection parameters should be properly set according to different situations.

#### 8.2.1 Operation overload fault protection(Over load)

After online operation, the integral value of  $\int x^2 \cdot t \cdot k$  is continuously calculated according to the standard overheat protection curve requirements specified in IEC60947-4-2 (see Figure 8.1) (where X represents the ratio of current to rated current of motor; T represents the current sampling period, k is the motor overload protection coefficient, which is related to the functional parameter F7.00 motor overload protection grade value, and the higher the overload protection grade, the smaller the k value).When the integral value of  $\int x^2 \cdot t \cdot k$  is greater than the overload protection value, "Operation overload fault" will be reported. See Table 8.1 for typical tripping schedule.

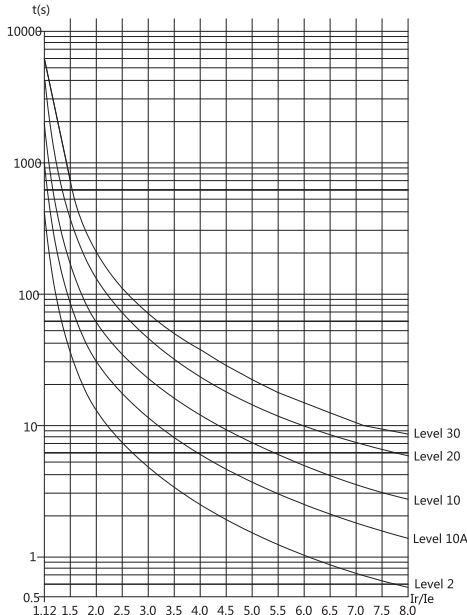

Figure 8.1 Standard thermal overload protection curve

**Table 8.1 Typical Trip Schedule**

	Trip time of standard application(level 10)				Trip time of heavy load application (level 20)			
current	200%le	300%le	400%le	500%le	200%le	300%le	400%le	500%le
time	60s	23s	14s	8s	120s	46s	28s	15s

**Note:** After the protection of " Over load " fault is reported, it must wait for 30 minutes before starting again.

#### 8.2.2 Locking/short circuit fault protection(Lock rotor/short)

Locked-rotor/short circuit protection includes load locked-rotor protection and load short circuit protection.

##### 8.2.2a) Lockup fault protection

Under the conditions of soft start, soft stop, online operation, low-speed forward rotation, low-speed reverse rotation or braking, it is detected that the effective value of current is greater than the set value of locked-rotor protection current F7.06 and the maintenance time is greater than the set value of locked-rotor time F7.07, and " Lock rotor/short " fault is reported.

##### 8.2.2b) Short-circuit fault protection

In soft start, soft stop, online operation, low-speed forward rotation, low-speed reverse rotation or braking state, when the peak current is detected to be more than 11 times the rated model current of the soft starter, the "locked rotor/short" fault will be reported immediately.

**Note:** Because of the long turn-off time of thyristor (determined by the inherent characteristics of thyristor turn-off), when short-circuit fault occurs, the thyristor may burn out.

#### 8.2.3 Starting current limit timeout fault protection(Limit I. timeout)

Under the conditions of soft start, soft stop, low-speed forward rotation or low-speed reverse rotation, the integral value of  $\int I^2 \cdot t$  is calculated continuously. When the integral value of  $\int I^2 \cdot t$  is greater than the current limit timeout value, a " Limit I. timeout " fault will be reported. See Table 8.2 for the relationship between the time and current of starting current limiting timeout protection, where  $I_r$  is the actual current value and  $I_e$  is the rated current value of the motor.

**Note 1:** When the soft start time is greater than 80s, the fault of too long start time will be reported.

**Note 2:** After the protection of " Limit I. timeout " fault is reported, it is necessary to wait for 30 minutes before starting again.

**Table 8.2 Timetable of Current Limiting Timeout Protection**

F0.00 set value Actual current	0: Level 2	1: level 10A	2: Level 10	3: Level 20	4: Level 30
500%le	25s	25s	25s	30s	40s
450% le	31s	31s	31s	37s	49s
400% le	39s	39s	39s	46s	62s
350% le	51s	51s	51s	61s	81s
300% le	69s	69s	69s	83s	111s
250% le	100s	100s	100s	120s	160s

#### 8.2.4 Three-phase unbalanced fault protection (Unbalance of I.)

Under the conditions of soft start, on-line operation, low-speed forward rotation and low-speed reverse rotation, when all phase current values are greater than 5%le, and the maintenance time is greater than the set value of the functional parameter F7.09 current three-phase unbalance time under the condition of  $I_{\min}/I_{\max} < (100-F7.08 \text{ set value})\%$ , a " Unbalance of I. " fault will be reported.

**Note 1:**  $I_{\min}$  represents the phase current with the smallest current and  $I_{\max}$  represents the phase current with the largest current.

**Note 2:** It is also possible to report three-phase unbalance fault when input phase failure occurs.

### 8.2.5 Output phase loss fault protection (Outp phase loss)

8.2.5a) During pre-starting, if it is detected that one phase of the motor is not connected with the output terminal of the soft starter, it will report " Output phase loss ".

8.2.5b) Under the conditions of soft start, on-line operation, low-speed forward rotation and low-speed reverse rotation, when all phase current values are greater than 5%I<sub>e</sub>, and the condition that I<sub>min</sub>/I<sub>max</sub> < 40% is met and the maintenance time is greater than 0.5s, an " Output phase loss " fault will be reported.

**Note 1: I<sub>min</sub> represents the phase current with the smallest current and I<sub>max</sub> represents the phase current with the largest current.**

**Note 2: It is also possible to report three-phase imbalance fault when input phase failure occurs.**

### 8.2.6 Input phase loss fault protection (Input phase loss)

During the pre-startup, it is detected that there is no input voltage in one or more phases within 1s, and the "Input phase loss " fault is reported.

### 8.2.7 Frequency fault protection (Frequency wrong)

8.2.7a) When the starting mode is not current mode (including normal current mode and enhanced current mode), it will report " Frequency wrong " fault when it is detected that the power grid frequency is not within the range of 50 Hz or 60 Hz.

8.2.7b) When the starting mode is current mode (including normal current mode and enhanced current mode), the frequency error fault will not be detected.

### 8.2.8 thyristor short-circuit fault protection (SCR short)

In the state of low-speed forward rotation or low-speed reverse rotation, when the phase current values are greater than 5%I<sub>e</sub>, the short circuit of any phase thyristor will be reported as " SCR short " fault.

### 8.2.9 Overheating protection of soft starter (SS over hot)

In any state (except the fault state), when the current temperature of the soft starter is detected to exceed the set value of the soft starter overheat protection value of functional parameter F7.11, a " SS over hot " fault will be reported. In the state of "soft starter overheating fault", if the temperature ratio function parameter F7 of soft starter is detected.1 When the set value of soft starter overheat protection value is lower than 2°C, the " SS over hot " fault will be automatically removed.

### 8.2.10 Motor overheat fault protection (Motor over hot)

In any state (except the fault state), the total resistance of the motor temperature sensor circuit is 200Ω~750Ω at 25°C. When the total resistance is greater than 3.1 kΩ, the "Motor over hot " fault will be reported, and when the total resistance is less than 1.5 kΩ, the motor overheating will be relieved.

### 8.2.11 Main circuit overvoltage fault protection (Main circuit OV)

In any state (except the fault state), when it is detected that the line voltage is greater than the set value of the main circuit overvoltage protection value of functional parameter F7.02 and the maintenance time is greater than the set value of the main circuit overvoltage filtering time of functional parameter F7.03, it will report " Main circuit OV. " fault .

### 8.2.12 Main circuit undervoltage fault protection (Main circuit UV)

In any state (except the fault state), when the line voltage is detected to be less than the set value of the main circuit undervoltage protection in functional parameter F7.04 and the maintenance time is longer than the set value of the main circuit undervoltage filtering time in functional parameter F7.05, a " Main circuit UV. " fault will be reported.

### 8.2.13 motherboard running timeout fault (CPU run timeout)

When it is detected that the internal polling period of motherboard software exceeds the set time, it will report " CPU run timeout " fault.

### 8.2.14 EMS terminal disconnection fault protection (EMS open fault)

In any state (except the fault state), it is detected that the disconnection time between terminals EMS and COM is greater than the set value of functional parameter F5.12 EMS terminal disconnection delay time, and report "EMS open fault"; When it is detected that the closing time between terminals EMS and COM is greater than the set value of functional parameter F5.11 EMS terminal closing delay time, the "EMS open fault" will be removed.

#### 8.2.15 Fault protection for excessive starting times (Too many starts)

When the set value of the function parameter F7.10 soft start times is equal to 0, the "Too many starts" fault will not be reported.

When the set value of soft-start times of functional parameter F7.10 is greater than 0, if the number of starts exceeds the set value of soft-start times of functional parameter F7.10 in one hour, it will report "Too many starts" fault.

#### 8.2.16 Fault protection for too long starting time (Too long start time)

When the accumulated time of the whole soft-start process exceeds 80s, "Too long start time" fault will be reported.

#### 8.2.17 Parameter error fault protection (Parameter wrong)

8.2.17a) When the values of readable and writable functional parameters (that is, the functional parameters of all parameter groups except FA group and FD group) exceed the parameter setting range, a "Parameter wrong" fault will be reported. In the "Parameter wrong" fault state, if it is detected that the values of all readable and writable functional parameters are within the parameter setting range, the "parameter error fault" will be automatically removed.

8.2.17b) When the set value of function selection of function parameter F5.01 input terminal IN1 is equal to the set value of function selection of function parameter F5.02 input terminal IN2, and the set value of function parameter F5.01 is equal to 1 or 2 or 3 or 4 or 5 or 6, a "parameter error fault" will be reported. In the state of "parameter error failure", if the set value of function parameter F5.01 is detected not equal to function parameter F5.02 or the setting values of functional parameters F5.01 and F5.02 are equal to "0", the "parameter error fault" will be automatically removed.

#### 8.2.18 External fault protection (External fault)

8.2.18a) When the set value of function selection of function parameter F5.01 input terminal IN1 is "1: External fault", and it is detected that the signal of IN1 terminal changes from off (the off time is greater than the set value of function parameter F5.04 IN1 terminal off delay time) to on (the on time is greater than the set value of function parameter F5.03 IN1 terminal on delay time), it will report "External fault". In the "external fault" state, if it is detected that the disconnection time of IN1 terminal signal is greater than the set value of functional parameter F5.04 IN1 terminal disconnection delay time, the "External fault" will be automatically removed.

8.2.18b) When the set value of function selection of function parameter F5.02 input terminal IN2 is "1: External fault", and it is detected that the signal of IN2 terminal changes from off (the off time is greater than the set value of function parameter F5.06 IN2 terminal off delay time) to on (the on time is greater than the set value of function parameter F5.05 IN2 terminal on delay time), "External fault" will be reported. In the "External fault" state, the "External fault" will be automatically relieved if the detection time of IN2 terminal signal disconnection is greater than the set value of functional parameter F5.06 IN2 terminal disconnection delay time.

#### 8.2.19 Overheating alarm of soft starter (SS OH. alarm)

In any state (except the fault state), when the temperature of the soft starter is detected to be greater than the set value of the soft starter overheat alarm value of functional parameter F7.12, a "SS OH. alarm" will be reported. In the state of "SS OH. alarm", if it is detected that the temperature of the soft starter is 2 °C lower than the set value of the function parameter F7.12, the "SS OH. alarm" will be automatically released.

**Note: SS will not stop in the state of "SS OH. alarm", and if "SS OH. alarm" has been reported in the ready state, it can not be soft started.**

### 8.2.20 Underload alarm (Under load alarm)

When the set value of the functional parameter F7.13 underload alarm current is equal to "0", "Under load alarm" will not be reported;

When the set value of the functional parameter F7.13 under-load alarm current is greater than "0", when it is detected that the current motor current is less than the set value of the functional parameter F7.13 under-load alarm current and the maintenance time is greater than the set value of the functional parameter F7.14 under-load current maintenance time, the product will report "under-load alarm", so the functional parameter F5.14 is set to "0:Any fault or alarm "or" 24: Under load alarm ",the K3 relay will act. Under the " Under load alarm" state, the " Under load alarm " will be automatically released when it is detected that the current current is greater than the set value of the functional parameter F7.13 and the holding time is greater than the set value of the functional parameter F7.15, so the functional parameter F5.14 is set to "0:Any fault or alarm "or" 24: Under load alarm ", the K3 relay will return to its original position.

**Note: Don't stop the machine in case of under-load alarm.**

### 8.3 Analysis and troubleshooting methods of common fault names

When the soft starter, load motor or power distribution equipment is abnormal, the fault protection function will act.

The fault name and related contents will be displayed on the screen. Please refer to the description in Table 8.3.

**Table 8.3 Cause analysis and troubleshooting methods of common fault names**

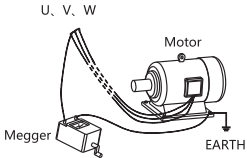
Fault name	Failure cause analysis	Troubleshooting method
Over load	1 Whether the load is too heavy or the load current often exceeds the rated current of the motor. 2 The motor rated current setting value is inappropriate.	1 check whether the load is too heavy (fan and water pump load adjustable channel valve opening Degree to adjust the load size), check whether the online running current exceeds the function. Parameter F2.01, F3.01 or F4.01 set value of rated current of motor; 2 Check the setting of motor rated current of functional parameters F2.01, F3.01 or F4.01. Whether the setting value is too low; 3 Check whether the motor current often exceeds the rated current value of the motor during online operation; 4 Check whether the deviation between the current value of the soft starter and the actual current value is large; 5 Seek technical support.
Lock rotor/short	1 Whether the load is too heavy or the load current often exceeds the rated current of the motor. 2 The motor rated current setting value is inappropriate. 3. Short circuit to ground or poor insulation of motor winding. 4. Short circuit or poor insulation between phases of motor windings.	1. Check whether the motor is locked; 2 Check whether the motor winding is short-circuited; 3. Check whether the motor winding is short-circuited to the ground. The inspection method is as follows:  4 Check whether the display current is within the range of locked-rotor protection current of functional parameter F7.06. 5 Seek technical support.

**Table 8.3 (Continued)**

Fault name	Failure cause analysis	Troubleshooting method
Limit I. timeout t	1 Whether the load is too heavy. 2. Whether the setting values of motor current limiting multiples of functional parameters F2.04, F3.04 and F4.04 are too small. 3. Whether the setting value of the initial voltage of the motor of functional parameters F2.07, F3.07 and F4.07 is too small. 4. Whether the setting values of the motor soft-start time factors of functional parameters F2.08, F3.08 and F4.08 are too large. 5 Whether the capacity of power grid transformer is insufficient.	1. Check whether the load is too heavy (fan and water pump load can adjust the opening of channel valve to adjust the load size); 2 Check whether the setting values of motor current limiting multiples of functional parameters F2.04, F3.04 and F4.04 are too small. 3 Check whether the set values of the initial voltage of the motor of functional parameters F2.07, F3.07 and F4.07 are too small. 4 Check whether the setting values of the motor soft-start time factors of functional parameters F2.08, F3.08 and F4.08 are too large. 5 Check whether the power supply capacity is insufficient, which leads to excessive voltage drop during soft starting. Under normal circumstances, the power supply capacity should be greater than 2.5 times of the motor power. 6. Seek technical support.
Unbalance of I.	1. Poor contact between output circuit and motor connection line. 2. Whether the input voltage of three-phase power grid is balanced. 3 Whether the thyristor is abnormal. 4 Soft starter motherboard is abnormal.	1 Check whether the output circuit and motor connection line are normal. 2 Check whether the three-phase input voltage of the power grid is balanced. 3. Check whether the thyristor is abnormal. Measure whether the main circuit terminals R and U, S and V, T and W are conductive with the conduction gear of multimeter in case of power failure, which indicates that the thyristor is abnormal; In addition, in case of power failure, use multimeter to test whether the resistance between G pole and K pole of each thyristor is normal and consistent. 4 Replace the motherboard. 5 Seek technical support.
Outp phase loss	1. Poor contact between output circuit and motor connection line. 2. Whether the input voltage of three-phase power grid is balanced and whether there is input phase loss. 3 Whether the thyristor is abnormal. 4 Soft starter motherboard is abnormal.	1. Check whether the three-phase input power supply and load motor are normal. 2. Check whether the input and output wiring of the soft starter is reliable. If there are circuit breakers and contactors in series in the main circuit, check whether the phases of the circuit breaker and contactor are closed or closed reliably. 3 check whether the three-phase input voltage of the power grid is balanced. 4. Check whether the thyristor is abnormal. In case of power failure, measure whether the main circuit terminals R and u, s and V, t and W are connected with each other by using the conduction gear of the multimeter. When conducting, it indicates that the thyristor is abnormal; In addition, in the case of power failure, use a multimeter to test whether the resistance value between the g-pole and the k-pole of each thyristor is normal and consistent. 5 replace the motherboard. 6. Seek technical support.

**Table 8.3 (Continued)**

Fault name	Failure cause analysis	Troubleshooting method
Input phase loss	1. Three phase input power supply and input circuit breaker are abnormal. 2. The output voltage and frequency are abnormal when the generator supplies power. 3 thyristor is abnormal. 4 Soft starter motherboard is abnormal.	1. Check whether the three-phase input power supply is normal or the wiring is poor. 2 check whether the grid frequency is within the normal range. 3. Check whether the thyristor is abnormal. Measure whether the main circuit terminals R and U, S and V, T and W are conductive with the conduction gear of multimeter in case of power failure, which indicates that the thyristor is abnormal; In addition, in case of power failure, use multimeter to test whether the resistance between G pole and K pole of each thyristor is normal and consistent. 4 Replace the motherboard. 5 Seek technical support.
Frequency wrong	1. The power of generator is insufficient or unstable. 2. The input frequency of power grid exceeds the normal range. 3. The main board of soft starter is abnormal.	1. Check whether the generator output grid frequency is stable in the normal range. 2 For non-generator power supply occasions, check whether the grid frequency is beyond the normal range. 3. Seek technical support.
SCR short	1 Whether the thyristor is short-circuited. 2 Poor contact between load motor and soft starter connection. 3 motherboard failure.	1 Check whether the SCR is short-circuited. 2 Check whether the load motor has poor contact with the connecting part of the soft starter. 3. Seek technical support.
SS over hot	1 Whether the load is too heavy. 2 Whether the starting is too frequent. 3 Whether the soft-start process is too long.	1. Check whether the load is too heavy (fan and water pump load can adjust the opening of channel valve to adjust the load). 2 Check whether there are too many starting times. 3 Whether the soft-start process is too long, which leads to serious product heat, the starting current limit multiple and initial voltage setting value can be appropriately increased, and the setting value of soft-start time factor can be appropriately decreased to improve the starting ability, so as to reduce the problems of soft-start process and serious heat. 4 Check whether the soft starter and load motor match in parameters. 5 Check whether the overheat protection value of soft starter is reasonable and can be set to the maximum value. 6. Seek technical support.
Motor over hot	1 Whether the load is too heavy. 2 Whether the starting is too frequent. 3 Whether the soft-start process is too long.	1. Check whether the load is too heavy (fan and water pump load can adjust the opening of channel valve to adjust the load). 2 Check whether there are too many starting times. 3 Whether the soft-start process is too long, which leads to serious product heat, the starting current limit multiple and initial voltage setting value can be appropriately increased, and the setting value of soft-start time factor can be appropriately decreased to improve the starting ability, so as to reduce the problems of soft-start process and serious heat.

**Table 8.3 (Continued)**

Fault name	Failure cause analysis	Troubleshooting method
		4 Check whether the soft starter and load motor match in parameters. 5 Check whether the overheat protection value of soft starter is reasonable and can be set to the maximum value. 6. Seek technical support.
Main circuit OV.	1 Whether the three-phase input voltage of the power grid is on the high side. 2 Whether the three-phase input voltage of the power grid fluctuates greatly. 3 Whether there is a super interference source.	1 Check whether the voltage of three-phase input power grid is on the high side. 2 Check whether the set value of the main circuit overvoltage protection value of functional parameter F7.02 is too low, and whether the main circuit overvoltage filtering time of functional parameter F7.03 is too small. 3. Check whether there is super interference load such as intermediate frequency furnace around the product. 4. Seek technical support.
Main circuit UV.	1 Power grid three-phase input voltage is low. 2 Whether the three-phase input voltage of the power grid fluctuates greatly. 3 Whether there is a super interference source.	1 Check whether the voltage of three-phase input power grid is high or low. 2. Check whether the set value of functional parameter F7.04 main circuit undervoltage protection value is set too high, and whether the undervoltage filtering time of functional parameter F7.05 main circuit is too short. 3. Check whether there is super interference load such as intermediate frequency furnace around the product. 4. Seek technical support.
Too many starts	The number of continuous starting times in one hour exceeds the set value of soft starting times of functional parameter F7.10	Check whether the number of continuous starting times in one hour exceeds the set value of soft starting times of functional parameter F7.10 (when F7.10 is greater than "0").
Too long start tim	1 Whether the load is too heavy. 2. Whether the setting values of motor current limiting multiples of functional parameters F2.04, F3.04 and F4.04 are too small. 3. Whether the setting value of the initial voltage of the motor of functional parameters F2.07, F3.07 and F4.07 is too small. 4. Whether the setting values of the motor soft-start time factors of functional parameters F2.08, F3.08 and F4.08 are too large. 5 Whether the capacity of power grid transformer is insufficient.	1. Check whether the load is too heavy (fan and water pump load can adjust the opening of channel valve to adjust the load size); 2 Check whether the setting values of motor current limiting multiples of functional parameters F2.04, F3.04 and F4.04 are too small. 3 Check whether the set values of the initial voltage of the motor of functional parameters F2.07, F3.07 and F4.07 are too small. 4 Check whether the setting values of the motor soft-start time factors of functional parameters F2.08, F3.08 and F4.08 are too large. 5 Check whether the power supply capacity is insufficient, which leads to excessive voltage drop during soft starting. Under normal circumstances, the power supply capacity should be greater than 2.5 times of the motor power. 6. Seek technical support.



**Table 8.3 (Continued)**

Fault name	Failure cause analysis	Troubleshooting method
Parameter wrong	1 Whether the parameter setting values of all writable and readable functions are beyond the parameter setting range. 2 Whether the set values of functional parameters F5.01 and F5.02 are accurate.	1. Check whether the function parameter setting value is within the parameter setting range or perform the operation of parameter restoration to factory value. 2 Check whether the set values of functional parameters F5.01 and F5.02 are accurate. 3. Seek technical support.
External fault	1 whether the set values of functional parameters F5.01 and F5.02 are correct. 2 Whether the external control terminals IN1 and IN2 are connected correctly.	1 Check whether the set values of functional parameters F5.01 and F5.02 are correct. 2 Check whether the external terminals IN1 and IN2 are connected correctly. 3. Seek technical support.
EMS open fault	1. Poor contact or no short circuit between EMS and COM of external control terminal. 2 soft starter motherboard problem.	1 Check whether the external control terminal EMS is disconnected from the COM terminal. 2 Check whether the normally closed contacts of other protection devices connected to this terminal are reliably closed. 3. Seek technical support.
SS OH. alarm	1 Whether the load is too heavy. 2 Whether the starting is too frequent. 3 Whether the soft-start process is too long.	1. Check whether the load is too heavy (fan and water pump load can adjust the opening of channel valve to adjust the load). 2 Check whether there are too many starting times. 3 Whether the soft-start process is too long, which leads to serious product heat, the starting current limit multiple and initial voltage setting value can be appropriately increased, and the setting value of soft-start time factor can be appropriately decreased to improve the starting ability, so as to reduce the problems of soft-start process and serious heat. 4 Check whether the soft starter and load motor match in parameters. 5 Check whether the overheat protection value of soft starter is reasonable and can be set to the maximum value. 6. Seek technical support.
Under load alarm	1 Function parameter F7.13 whether the setting value of underload alarm current is too big. 2 Whether the motor load current is too small. 3 The display current of soft starter is less than the actual current.	1 Check whether the setting value of the function parameter F7.13 under-load alarm current is too small (setting it to "0" means that this function is blocked). 2 Check whether the load is too light. 3. Seek technical support.

#### 8.4 Analysis and elimination methods of common abnormal phenomena

See Table 8.4 for reasons analysis and elimination methods of abnormal phenomena.

**Table 8.4 Analysis and Elimination Methods of Common Abnormal Phenomena**

Common abnormal phenomena	Failure cause analysis	Troubleshooting method
The external control terminal cannot be started.	<ol style="list-style-type: none"> <li>1 The setting value of functional parameter F1.00 start/stop channel is incorrect.</li> <li>2 Terminals RUN, STOP and COM are not closed or in poor contact.</li> </ol>	<ol style="list-style-type: none"> <li>1 Check whether the parameter F1.00 is set correctly.</li> <li>2 Check whether the terminals STOP, RUN and COM are connected normally and reliably;</li> <li>3. Seek technical support.</li> </ol>
Remote communication cannot be started.	<ol style="list-style-type: none"> <li>1 The setting value of functional parameter F1.00 start/stop channel is incorrect.</li> <li>2 Terminals 485+, 485- are abnormally connected with 485+, 485- of the upper computer.</li> <li>3 The communication address, baud rate, data format, etc. do not match the upper computer.</li> </ol>	<ol style="list-style-type: none"> <li>1 check whether the parameter F1.00 is set correctly.</li> <li>2 Check whether the connections between terminals 485+ and 485- and the upper computer 485+ and 485- are reliable.</li> <li>3 Check whether the communication address, baud rate, data format, etc. match with the upper computer.</li> <li>4. Seek technical support.</li> </ol>
During online operation Stop suddenly.	<ol style="list-style-type: none"> <li>1 Whether the external control terminals RUN, STOP and COM are accidentally disconnected or have poor contact.</li> <li>2 Failure occurred during online operation.</li> <li>3. The main board of soft starter is abnormal.</li> </ol>	<ol style="list-style-type: none"> <li>1 When the external control start/STOP is allowed, check whether the external control terminals RUN, Stop and COM are accidentally disconnected or have poor contact.</li> <li>2 Check whether the intermediate relays of the control terminals RUN, STOP and COM are reliably closed or disconnected, especially when the vibration is serious.</li> <li>3. Whether there is any unexpected action of the intermediate relay that controls the actions of RUN, STOP and COM due to the voltage drop of the power grid during online operation.</li> <li>4 Check whether there is any fault information on the operation interface or whether there is a new fault in the functional parameter FD.00</li> <li>5 Seek technical support.</li> </ol>
The motor speed can't rise when it starts.	<ol style="list-style-type: none"> <li>1 Whether the load is too heavy.</li> <li>2. Whether the setting values of motor current limiting multiples of functional parameters F2.04, F3.04 and F4.04 are too small.</li> <li>3. Whether the setting value of the initial voltage of the motor of functional parameters F2.07, F3.07 and F4.07 is too small.</li> <li>4. Whether the setting values of the motor soft-start time factors of functional parameters F2.08, F3.08 and F4.08 are too large.</li> <li>5 Whether the capacity of power grid transformer is insufficient.</li> </ol>	<ol style="list-style-type: none"> <li>1. Check whether the load is too heavy (fan and water pump load can adjust the opening of channel valve to adjust the load size);</li> <li>2 Check whether the setting values of motor current limiting multiples of functional parameters F2.04, F3.04 and F4.04 are too small.</li> <li>3 Check whether the set values of the initial voltage of the motor of functional parameters F2.07, F3.07 and F4.07 are too small.</li> <li>4 Check whether the setting values of the motor soft-start time factors of functional parameters F2.08, F3.08 and F4.08 are too large.</li> <li>5 Check whether the power supply capacity is insufficient, which leads to excessive voltage drop during soft starting. Under normal circumstances, the power supply capacity should be greater than 2.5 times of the motor power.</li> <li>6. Seek technical support.</li> </ol>

## **9** Warranty period and environmental protection

### **9.1** Warranty period

12 months from the date of purchase or 18 months from the date of production, whichever comes first. If the following situations occur, it is not covered by the warranty:

- A. damage caused by improper use, storage and maintenance by users;
- B damage caused by force majeure factors (fire, flood, earthquake, abnormal voltage, etc.);
- C. Damage caused by improper selection or use of soft starter for abnormal functions;
- D. Damage caused by non-company-assigned institutions or person, or self-disassembly and maintenance;
- E. the product exceeds the warranty period.

### **9.2** Environmental protection

In order to protect the environment, when this product or its components are scrapped, please properly dispose of it as industrial waste or hand it over to a recycling station for classification, disassembly, recycling and reuse according to relevant national regulations.

## Appendix A Recommended Table of Peripheral Device Configuration

Soft starter model	SS Rated current	Motor rated current	Motor rated power	Circuit breaker model (3P motor protection type)	Cable Or copper bar.	Short-circuit current	Fuse protector (SCP)
NJR5-15/ZX2	15A	15A	4kW	NM1-63/20A	Cable line: 4mm <sup>2</sup>	reserve	reserve
NJR5-22/ZX2	22A	22A	5.5kW	NM1-63/32A	Cable line: 6 mm <sup>2</sup>	reserve	reserve
NJR5-30/ZX2	30A	29A	7.5kW	NM1-63/40A	Cable line: 10 mm <sup>2</sup>	reserve	reserve
NJR5-37/ZX2	37A	36A	11kW	NM1-63/50A	Cable line: 10 mm <sup>2</sup>	reserve	reserve
NJR5-44/ZX2	44A	42A	11kW	NM1-63/63A	Cable line: 16 mm <sup>2</sup>	reserve	reserve
NJR5-60/ZX2	60A	57A	15kW	NM1-100/80A	Cable line: 25 mm <sup>2</sup>	reserve	reserve
NJR5-74/ZX2	74A	70A	18.5kW	NM1-100/100A	Cable line: 35 mm <sup>2</sup>	reserve	reserve
NJR5-90/ZX2	90A	84A	22kW	NM1-250/125A	Cable line: 35 mm <sup>2</sup>	3kA	NGT1-160A
NJR5-110/ZX2	110A	103A	30kW	NM1-250/160A	Cable line: 50 mm <sup>2</sup>	reserve	reserve
NJR5-150/ZX2	150A	140A	37kW	NM1-250/200A	Cable line: 50 mm <sup>2</sup>	5kA	NGT2-250A
NJR5-180/ZX2	180A	167A	45kW	NM1-250/225A	Copper bar: 30×3 mm <sup>2</sup>	reserve	reserve
NJR5-220/ZX2	220A	207A	55kW	NM1-400/315A	Copper bar: 30×3 mm <sup>2</sup>	reserve	reserve
NJR5-264/ZX2	264A	248A	75kW	NM1-400/315A	Copper bar: 30×4 mm <sup>2</sup>	reserve	reserve
NJR5-320/ZX2	320A	300A	90kW	NM1-400/350A	Copper bar: 30×4 mm <sup>2</sup>	reserve	reserve
NJR5-370/ZX2	370A	349A	110kW	NM1-630/500A	Copper bar: 40×4 mm <sup>2</sup>	5kA	RS77C-630A
NJR5-440/ZX2	440A	404A	110kW	NM1-630/630A	Copper bar: 40×4 mm <sup>2</sup>	reserve	reserve
NJR5-500/ZX2	500A	459A	132kW	NM1-630/630A	Copper bar: 40×5 mm <sup>2</sup>	reserve	reserve
NJR5-560/ZX2	560A	514A	160kW	NM1-630/630A	Copper bar: 40×5 mm <sup>2</sup>	reserve	reserve
NJR5-630/ZX2	630A	579A	160kW	NM1-800/700A	Copper bar: 40×6 mm <sup>2</sup>	reserve	reserve
NJR5-710/ZX2	710A	634A	200kW	NM1-800/700A	Copper bar: 40×8 mm <sup>2</sup>	10kA	RS77C-900A
NJR5-800/ZX2	800A	720A	200kW	NM1-800/700A	Copper bar: 40×8 mm <sup>2</sup>	reserve	reserve
NJR5-900/ZX2	900A	810A	250kW	NM1-1250/1250A	Copper bar: 40×10 mm <sup>2</sup>	reserve	reserve
NJR5-1000/ZX2	1000A	900A	250kW	NM1-1250/1250A	Copper bar: 40×10 mm <sup>2</sup>	10kA	RS77C-900A
NJR5-15/ZX3	15A	15A	7.5kW	NM1-63/20A	Cable line: 4mm <sup>2</sup>	reserve	reserve
NJR5-22/ZX3	22A	22A	11kW	NM1-63/32A	Cable line: 6 mm <sup>2</sup>	reserve	reserve
NJR5-30/ZX3	30A	29A	15kW	NM1-63/40A	Cable line: 10 mm <sup>2</sup>	reserve	reserve
NJR5-37/ZX3	37A	36A	18.5kW	NM1-63/50A	Cable line: 10 mm <sup>2</sup>	reserve	reserve
NJR5-44/ZX3	44A	42A	22kW	NM1-63/63A	Cable line: 16 mm <sup>2</sup>	reserve	reserve
NJR5-60/ZX3	60A	57A	30kW	NM1-100/80A	Cable line: 25 mm <sup>2</sup>	reserve	reserve
NJR5-74/ZX3	74A	70A	37kW	NM1-100/100A	Cable line: 35 mm <sup>2</sup>	reserve	reserve
NJR5-90/ZX3	90A	84A	45kW	NM1-250/125A	Cable line: 35 mm <sup>2</sup>	3kA	NGT1-160A
NJR5-110/ZX3	110A	103A	55kW	NM1-250/160A	Cable line: 50 mm <sup>2</sup>	reserve	reserve
NJR5-150/ZX3	150A	140A	75kW	NM1-250/200A	Cable line: 50 mm <sup>2</sup>	5kA	NGT2-250A
NJR5-180/ZX3	180A	167A	90kW	NM1-250/225A	Copper bar: 30×3 mm <sup>2</sup>	reserve	reserve
NJR5-220/ZX3	220A	207A	110kW	NM1-400/315A	Copper bar: 30×3 mm <sup>2</sup>	reserve	reserve
NJR5-264/ZX3	264A	248A	132kW	NM1-400/315A	Copper bar: 30×4 mm <sup>2</sup>	reserve	reserve
NJR5-320/ZX3	320A	300A	160kW	NM1-400/350A	Copper bar: 30×4 mm <sup>2</sup>	reserve	reserve
NJR5-370/ZX3	370A	349A	185kW	NM1-630/500A	Copper bar: 40×4 mm <sup>2</sup>	5kA	RS77C-630A
NJR5-440/ZX3	440A	404A	220kW	NM1-630/630A	Copper bar: 40×4 mm <sup>2</sup>	reserve	reserve
NJR5-500/ZX3	500A	459A	250kW	NM1-630/630A	Copper bar: 40×5 mm <sup>2</sup>	reserve	reserve
NJR5-560/ZX3	560A	514A	280kW	NM1-630/630A	Copper bar: 40×5 mm <sup>2</sup>	reserve	reserve
NJR5-630/ZX3	630A	579A	315kW	NM1-800/700A	Copper bar: 40×6 mm <sup>2</sup>	reserve	reserve
NJR5-710/ZX3	710A	634A	355kW	NM1-800/700A	Copper bar: 40×8 mm <sup>2</sup>	10kA	RS77C-900A

Soft starter model	SS Rated current	Motor rated current	Motor rated power	Circuit breaker model (3P motor protection type)	Cable Or copper bar.	Short-circuit current	Fuse protector (SCPD)
NJR5-800/ZX3	800A	720A	400kW	NM1-800/700A	Copper bar: 40×8 mm <sup>2</sup>	reserve	reserve
NJR5-900/ZX3	900A	810A	450kW	NM1-1250/1250A	Copper bar: 40×10 mm <sup>2</sup>	reserve	reserve
NJR5-1000/ZX3	1000A	900A	500kW	NM1-1250/1250A	Copper bar: 40×10 mm <sup>2</sup>	10kA	RS77C-900A
NJR5-15/ZX4	15A	15A	9kW	NM1-63/20A	Cable line: 4mm <sup>2</sup>	reserve	reserve
NJR5-22/ZX4	22A	22A	15kW	NM1-63/32A	Cable line: 6 mm <sup>2</sup>	reserve	reserve
NJR5-30/ZX4	30A	29A	18.5kW	NM1-63/40A	Cable line: 10 mm <sup>2</sup>	reserve	reserve
NJR5-37/ZX4	37A	36A	22kW	NM1-63/50A	Cable line: 10 mm <sup>2</sup>	reserve	reserve
NJR5-44/ZX4	44A	42A	30kW	NM1-63/63A	Cable line: 16 mm <sup>2</sup>	reserve	reserve
NJR5-60/ZX4	60A	57A	37kW	NM1-100/80A	Cable line: 25 mm <sup>2</sup>	reserve	reserve
NJR5-74/ZX4	74A	70A	45kW	NM1-100/100A	Cable line: 35 mm <sup>2</sup>	reserve	reserve
NJR5-90/ZX4	90A	84A	55kW	NM1-250/125A	Cable line: 35 mm <sup>2</sup>	3kA	NGT1-160A
NJR5-110/ZX4	110A	103A	75kW	NM1-250/160A	Cable line: 50 mm <sup>2</sup>	reserve	reserve
NJR5-150/ZX4	150A	140A	90kW	NM1-250/200A	Cable line: 50 mm <sup>2</sup>	5kA	NGT2-250A
NJR5-180/ZX4	180A	167A	110kW	NM1-250/225A	Copper bar: 30×3 mm <sup>2</sup>	reserve	reserve
NJR5-220/ZX4	220A	207A	132kW	NM1-400/315A	Copper bar: 30×3 mm <sup>2</sup>	reserve	reserve
NJR5-264/ZX4	264A	248A	150kW	NM1-400/315A	Copper bar: 30×4 mm <sup>2</sup>	reserve	reserve
NJR5-320/ZX4	320A	300A	185kW	NM1-400/350A	Copper bar: 30×4 mm <sup>2</sup>	reserve	reserve
NJR5-370/ZX4	370A	349A	220kW	NM1-630/500A	Copper bar: 40×4 mm <sup>2</sup>	5kA	RS77C-630A
NJR5-440/ZX4	440A	404A	250kW	NM1-630/630A	Copper bar: 40×4 mm <sup>2</sup>	reserve	reserve
NJR5-500/ZX4	500A	459A	280kW	NM1-630/630A	Copper bar: 40×5 mm <sup>2</sup>	reserve	reserve
NJR5-560/ZX4	560A	514A	315kW	NM1-630/630A	Copper bar: 40×5 mm <sup>2</sup>	reserve	reserve
NJR5-630/ZX4	630A	579A	355kW	NM1-800/700A	Copper bar: 40×6 mm <sup>2</sup>	reserve	reserve
NJR5-710/ZX4	710A	634A	400kW	NM1-800/700A	Copper bar: 40×8 mm <sup>2</sup>	10kA	RS77C-900A
NJR5-800/ZX4	800A	720A	450kW	NM1-800/700A	Copper bar: 40×8 mm <sup>2</sup>	reserve	reserve
NJR5-900/ZX4	900A	810A	560kW	NM1-1250/1250A	Copper bar: 40×10 mm <sup>2</sup>	reserve	reserve
NJR5-1000/ZX4	1000A	900A	560kW	NM1-1250/1250A	Copper bar: 40×10 mm <sup>2</sup>	10kA	RS77C-900A
NJR5-15/ZX5	15A	15A	11kW	NM1-100/20A	Cable line: 4mm <sup>2</sup>	reserve	reserve
NJR5-22/ZX5	22A	22A	18.5kW	NM1-100/32A	Cable line: 6 mm <sup>2</sup>	reserve	reserve
NJR5-30/ZX5	30A	29A	22kW	NM1-100/40A	Cable line: 10 mm <sup>2</sup>	reserve	reserve
NJR5-37/ZX5	37A	36A	30kW	NM1-100/50A	Cable line: 10 mm <sup>2</sup>	reserve	reserve
NJR5-44/ZX5	44A	42A	30kW	NM1-100/63A	Cable line: 16 mm <sup>2</sup>	reserve	reserve
NJR5-60/ZX5	60A	57A	45kW	NM1-100/80A	Cable line: 25 mm <sup>2</sup>	reserve	reserve
NJR5-74/ZX5	74A	70A	55kW	NM1-100/100A	Cable line: 35 mm <sup>2</sup>	reserve	reserve
NJR5-90/ZX5	90A	84A	75kW	NM1-250/125A	Cable line: 35 mm <sup>2</sup>	3kA	NGT1-160A
NJR5-110/ZX5	110A	103A	75kW	NM1-250/160A	Cable line: 50 mm <sup>2</sup>	reserve	reserve
NJR5-150/ZX5	150A	140A	110kW	NM1-250/200A	Cable line: 50 mm <sup>2</sup>	5kA	NGT2-250A
NJR5-180/ZX5	180A	167A	132kW	NM1-250/225A	Copper bar: 30×3 mm <sup>2</sup>	reserve	reserve
NJR5-220/ZX5	220A	207A	160kW	NM1-400/315A	Copper bar: 30×3 mm <sup>2</sup>	reserve	reserve
NJR5-264/ZX5	264A	248A	185kW	NM1-400/315A	Copper bar: 30×4 mm <sup>2</sup>	reserve	reserve
NJR5-320/ZX5	320A	300A	250kW	NM1-400/350A	Copper bar: 30×4 mm <sup>2</sup>	reserve	reserve
NJR5-370/ZX5	370A	349A	280kW	NM1-630/500A	Copper bar: 40×4 mm <sup>2</sup>	5kA	RS77C-630A
NJR5-440/ZX5	440A	404A	315kW	NM1-630/630A	Copper bar: 40×4 mm <sup>2</sup>	reserve	reserve
NJR5-500/ZX5	500A	459A	355kW	NM1-630/630A	Copper bar: 40×5 mm <sup>2</sup>	reserve	reserve
NJR5-560/ZX5	560A	514A	400kW	NM1-630/630A	Copper bar: 40×5 mm <sup>2</sup>	reserve	reserve
NJR5-630/ZX5	630A	579A	450kW	NM1-800/700A	Copper bar: 40×6 mm <sup>2</sup>	reserve	reserve

Soft starter model	SS Rated current	Motor rated current	Motor rated power	Circuit breaker model (3P motor protection type)	Cable Or copper bar.	Short-circuit current	Fuse protector (SCPD)
NJR5-710/ZX5	710A	634A	500kW	NM1-800/700A	Copper bar: 40×8 mm <sup>2</sup>	10kA	RS77C-900A
NJR5-800/ZX5	800A	720A	560kW	NM1-800/700A	Copper bar: 40×8 mm <sup>2</sup>	reserve	reserve
NJR5-900/ZX5	900A	810A	630kW	NM1-1250/1250A	Copper bar: 40×10 mm <sup>2</sup>	reserve	reserve
NJR5-1000/ZX5	1000A	900A	800kW	NM1-1250/1250A	Copper bar: 40×10 mm <sup>2</sup>	10kA	RS77C-900A
NJR5-15/ZX6	15A	15A	11kW	NM1-100/20A	Cable line: 4mm <sup>2</sup>	reserve	reserve
NJR5-22/ZX6	22A	22A	18.5kW	NM1-100/32A	Cable line: 6 mm <sup>2</sup>	reserve	reserve
NJR5-30/ZX6	30A	29A	22kW	NM1-100/40A	Cable line: 10 mm <sup>2</sup>	reserve	reserve
NJR5-37/ZX6	37A	36A	30kW	NM1-100/50A	Cable line: 10 mm <sup>2</sup>	reserve	reserve
NJR5-44/ZX6	44A	42A	37kW	NM1-100/63A	Cable line: 16 mm <sup>2</sup>	reserve	reserve
NJR5-60/ZX6	60A	57A	55kW	NM1-100/80A	Cable line: 25 mm <sup>2</sup>	reserve	reserve
NJR5-74/ZX6	74A	70A	75kW	NM1-100/100A	Cable line: 35 mm <sup>2</sup>	reserve	reserve
NJR5-90/ZX6	90A	84A	90kW	NM1-250/125A	Cable line: 35 mm <sup>2</sup>	3kA	NGT1-160A
NJR5-110/ZX6	110A	103A	110kW	NM1-250/160A	Cable line: 50 mm <sup>2</sup>	reserve	reserve
NJR5-150/ZX6	150A	140A	132kW	NM1-250/200A	Cable line: 50 mm <sup>2</sup>	5kA	NGT2-250A
NJR5-180/ZX6	180A	167A	160kW	NM1-250/225A	Copper bar: 30×3 mm <sup>2</sup>	reserve	reserve
NJR5-220/ZX6	220A	207A	200kW	NM1-400/315A	Copper bar: 30×3 mm <sup>2</sup>	reserve	reserve
NJR5-264/ZX6	264A	248A	250kW	NM1-400/315A	Copper bar: 30×4 mm <sup>2</sup>	reserve	reserve
NJR5-320/ZX6	320A	300A	315kW	NM1-400/350A	Copper bar: 30×4 mm <sup>2</sup>	reserve	reserve
NJR5-370/ZX6	370A	349A	355kW	NM1-630/500A	Copper bar: 40×4 mm <sup>2</sup>	5kA	RS77C-630A
NJR5-440/ZX6	440A	404A	400kW	NM1-630/630A	Copper bar: 40×4 mm <sup>2</sup>	reserve	reserve
NJR5-500/ZX6	500A	459A	400kW	NM1-630/630A	Copper bar: 40×5 mm <sup>2</sup>	reserve	reserve
NJR5-560/ZX6	560A	514A	500kW	NM1-630/630A	Copper bar: 40×5 mm <sup>2</sup>	reserve	reserve
NJR5-630/ZX6	630A	579A	560kW	NM1-800/700A	Copper bar: 40×6 mm <sup>2</sup>	reserve	reserve
NJR5-710/ZX6	710A	634A	630kW	NM1-800/700A	Copper bar: 40×8 mm <sup>2</sup>	10kA	RS77C-900A
NJR5-800/ZX6	800A	720A	710kW	NM1-800/700A	Copper bar: 40×8 mm <sup>2</sup>	reserve	reserve
NJR5-900/ZX6	900A	810A	800kW	NM1-1250/1250A	Copper bar: 40×10 mm <sup>2</sup>	reserve	reserve
NJR5-1000/ZX6	1000A	900A	900kW	NM1-1250/1250A	Copper bar: 40×10 mm <sup>2</sup>	10kA	RS77C-900A

## Appendix B Application

### B.1 One-for-one basic wiring diagram (see Figure B.1)

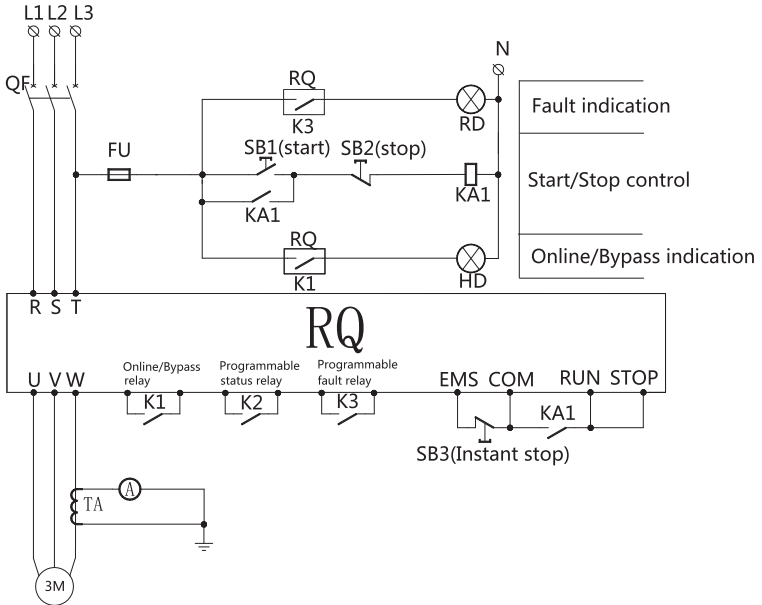

Figure B.1 One-for-one basic wiring diagram

Note 1: Because the maximum contact capacity of relay K1 is 5A, if you want to control high-power contactors, you must add an intermediate relay.

Note 2: Because the soft starter itself has overload protection, KH thermal relay can be omitted in the application of "one-for-one".

Note 3: Please set the function parameters according to the factory values to realize the above functions.

**B.2** basic wiring diagram of one-for-two

B.2.1 See Figure B.2 for the main circuit diagram of one – for - two.

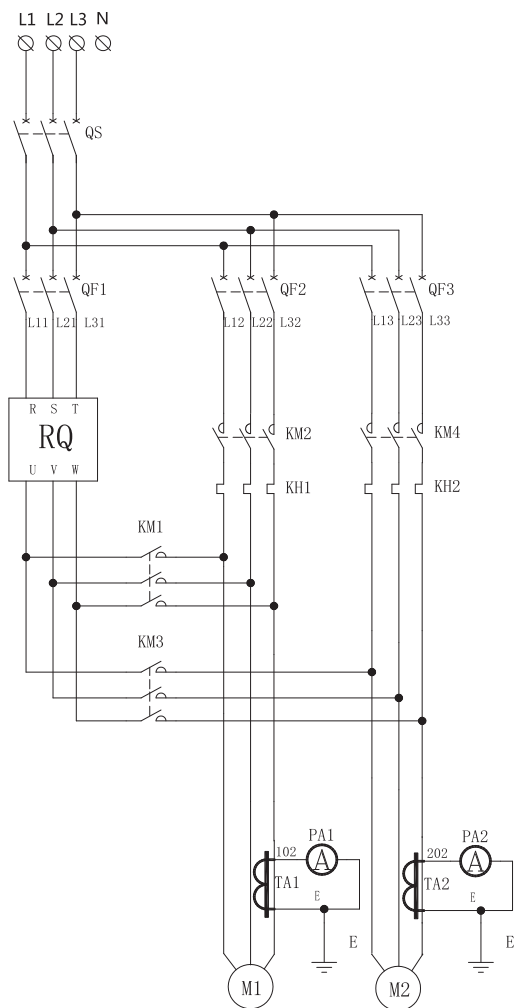

**Figure B.2** See figure for the main circuit diagram of one for two.



B.2.2 Refer to Figure B.3 for the control circuit diagram of one-for-two.

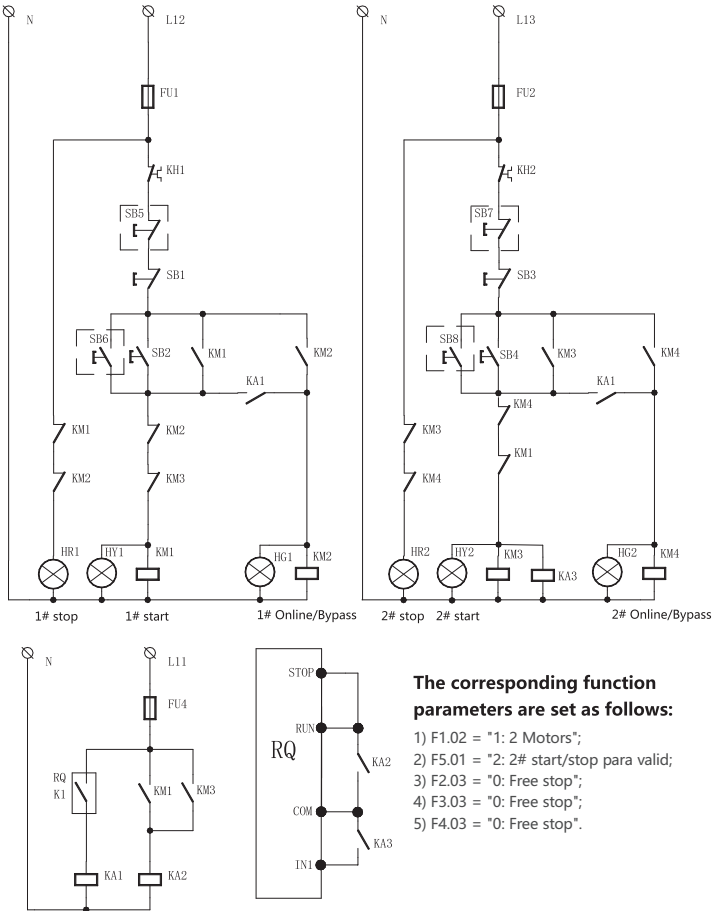

**Figure B.3 One-for-two control circuit diagram**

**Note:** The virtual box contains the remote control node.

**Note:** KH thermal relay must be installed separately for each motor.

**B.3 One-for-three basic wiring diagram**

B.3.1 See Figure B.4 for the circuit diagram of one-for-three main circuits.

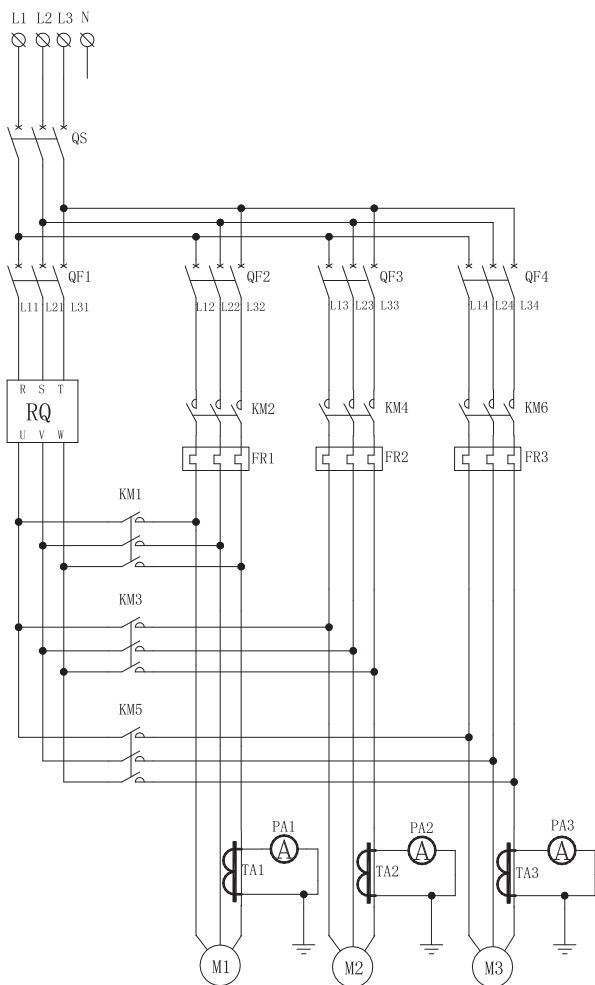

**B.4 Circuit diagram of one-for-three main circuits**

B.3.2 See Figure B.5 for the diagram of one-for-three control circuit.

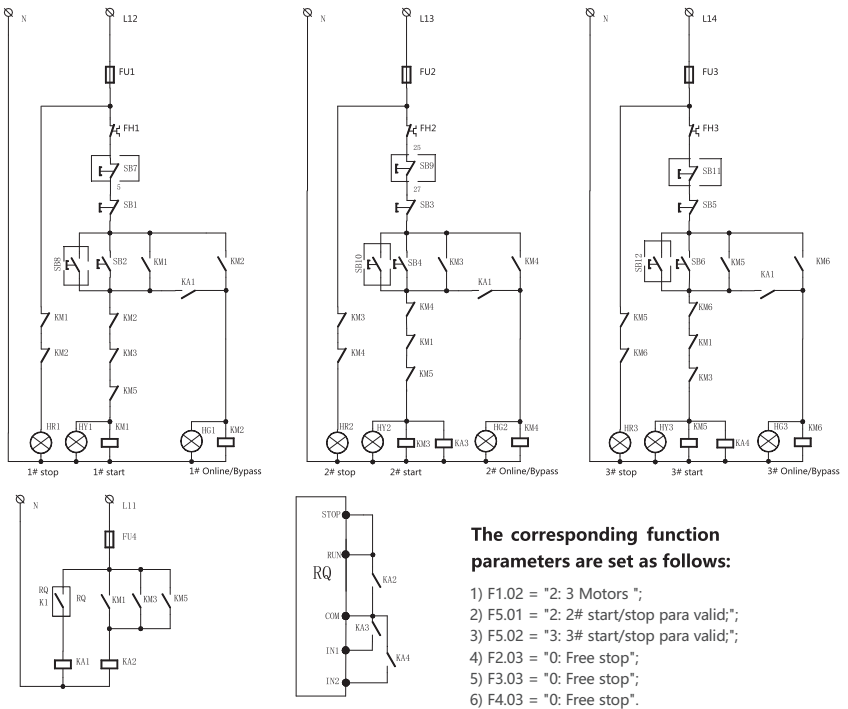

**Figure B.5 One-for-three control circuit diagram**

**Note:** The virtual box contains the remote control node.

**Note:** KH thermal relay must be installed separately for each motor.

**Appendix C version change record form**

Version date after change	Version number after change	Change content
2022-08	V1.00	First issue
2023-03	V1.10	First modification

**CHINT**

**QC PASS**

NJR5-ZX series  
Soft starter  
GB / T 14048.6、  
EN 60947-4-2

**Check 05**

---

Test date: Please see the packing

---

**ZHEJIANG CHINT ELECTRICS CO., LTD.**

---

**CHINT**

CHINT ELECTRICS

NJR5-ZX Series  
Soft starter  
User Manual

**Zhejiang Chint Electrics Co., Ltd.**

Add: No.1, CHINT Road, CHINT Industrial Zone, North Baixiang,

Yueqing, Zhejiang 325603, P.R.China

E-mail: [global-sales@chint.com](mailto:global-sales@chint.com)

Website: <http://en.chint.com>

