



## NU6-III Low-voltage Surge Arrester

### 1. General

- 1.1 Certificates: international certificates are under proceeding;
- 1.2 Electric ratings: Single phase power distribution and control system of AC50Hz, 230V;
- 1.3 Short circuit current: up to 5kA (8/20μs);
- 1.4 Application: Protect electric system and on-loading electrical apparatus from lightning and instantaneous over-voltage;
- 1.5 Standard : IEC61643-1, EN61643-11



### 2. Technical data

Model	Uoc (1.2/50μs) (kV)	Short circuit current Isc (8/20us)(KA)	Max. continuous operational voltage Uc (V~)	Level of protection Up (kV)
NU6-III	10	5	275	1.5
			320	1.5
			385	1.5

Auxiliary contact	Configurations	Rated voltage Un(V)	Rated current In(A)
contact	INO+INC	AC125	3

### 3. Type and circuit diagram

Model	Type	Circuit diagram
NU6-III	1P+N 	Compound Type 
	2P 	Compound Type 

#### 4. Design type and protective mode of different surge protectors

Model	Uoc (1.2/50μs) (kV)	Uc (V~)	Corresponding design type and protection mode
NU6-III	10	275	Compound type (with gasdischarge tube + voltage sensitive resistance) L-N/N-PE
		320	Compound type (with gas discharge tube + voltage sensitive resistance) L-PE/N-PE
		385	

#### 5. Functions

- 5.1 The product is composed of two independent components: removable protective module 4 and base 2;
- 5.2 When the product is damaged, the part 3 will indicate; please replace the removable protective module 4 at once and there is no need to cutoff the circuits;
- 5.3 The part 1 is for maximum continuous operational voltage indication as well as avoiding replacement with wrong module.

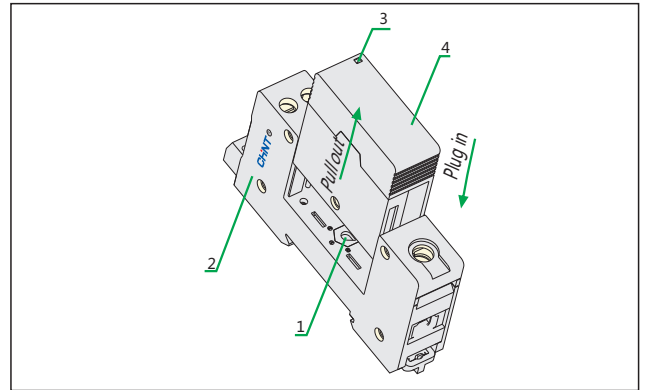

NU6-III/F with remote control port

#### 6. Overall and mounting dimensions (mm)

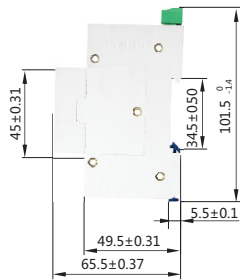

← Auxiliary contact

NU6-III without remote control port

